

ROUTE 4 CONTINUED

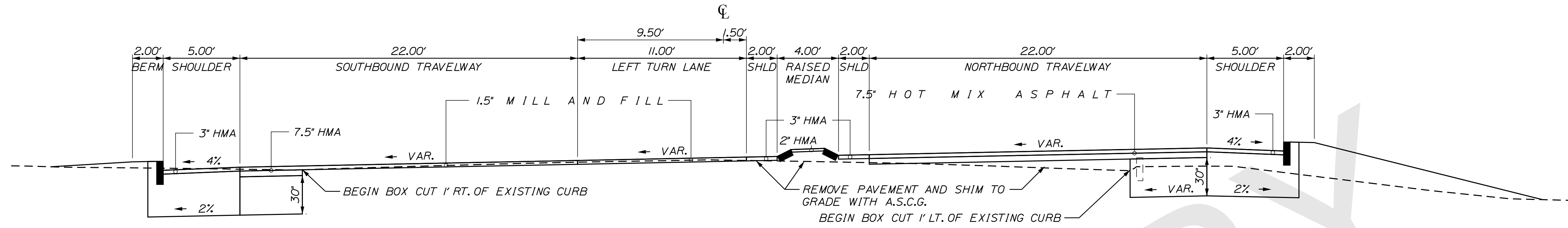

SUPERELEVATED
SOUTHBOUND LEFT TURN LANE

22' - 22' TRAVELWAY
STATION TO STATION
15+45.50 TO 16+20.00

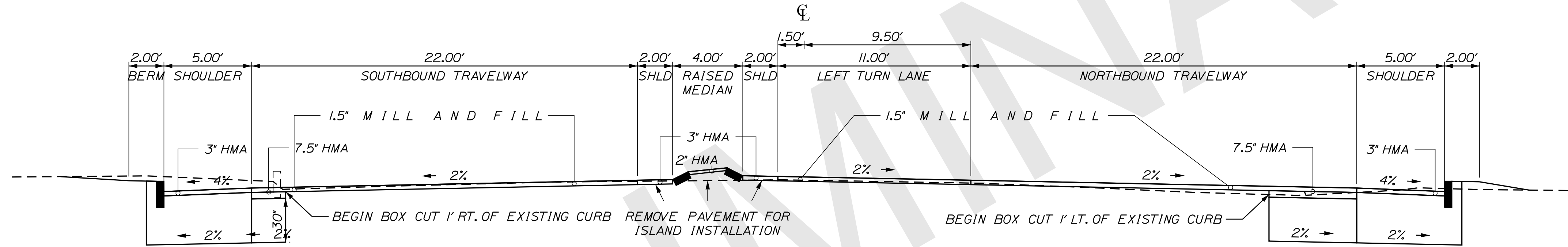

NORMAL
NORTHBOUND LEFT TURN LANE

22' - 22' TRAVELWAY WITH MEDIAN
STATION TO STATION

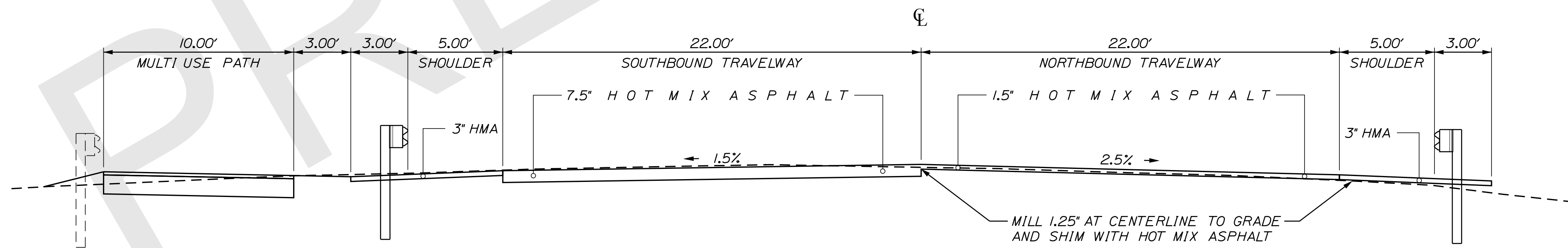

NORMAL
LAKE AUBURN CAUSEWAY

22' - 22' TRAVELWAY WITH GUARDRAIL AND MULTI USE PATH
STATION TO STATION

Date: 11/18/2019

Username: clark.e.sullivan

Division: HIGHWAY

Filename: ... \HIGHWAY\MSTA003_Typical2.dgn

STATE OF MAINE
DEPARTMENT OF TRANSPORTATION

WIN WIN 021766.00
HIGHWAY PLANS

PROJ. MANAGER	DESIGN-DETAILED	CHECKED-REVIEWED	DESIGN-DETAILED	DESIGN-DETAILED	REVISIONS 1	REVISIONS 2	REVISIONS 3	REVISIONS 4	FIELD CHANGES
BY	DATE	BY	DATE	BY	DATE	BY	DATE	BY	DATE
SIGNATURE	P.E. NUMBER	DATE							

AUBURN
ROUTE 4

TYPICAL SECTIONS

SHEET NUMBER

© SHEET

NOT TO SCALE

OF _

SIDE ROADS

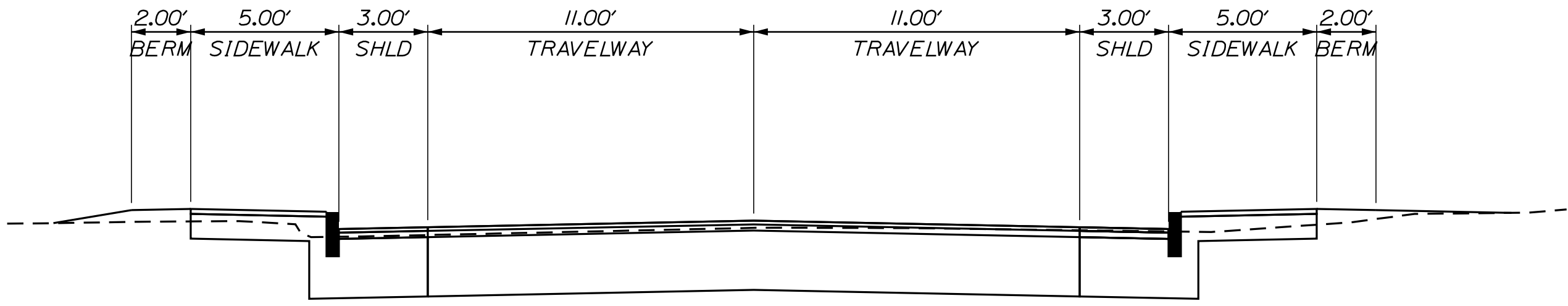

OAK HILL ROAD

11' - 11' TRAVELWAY
STATION TO STATION

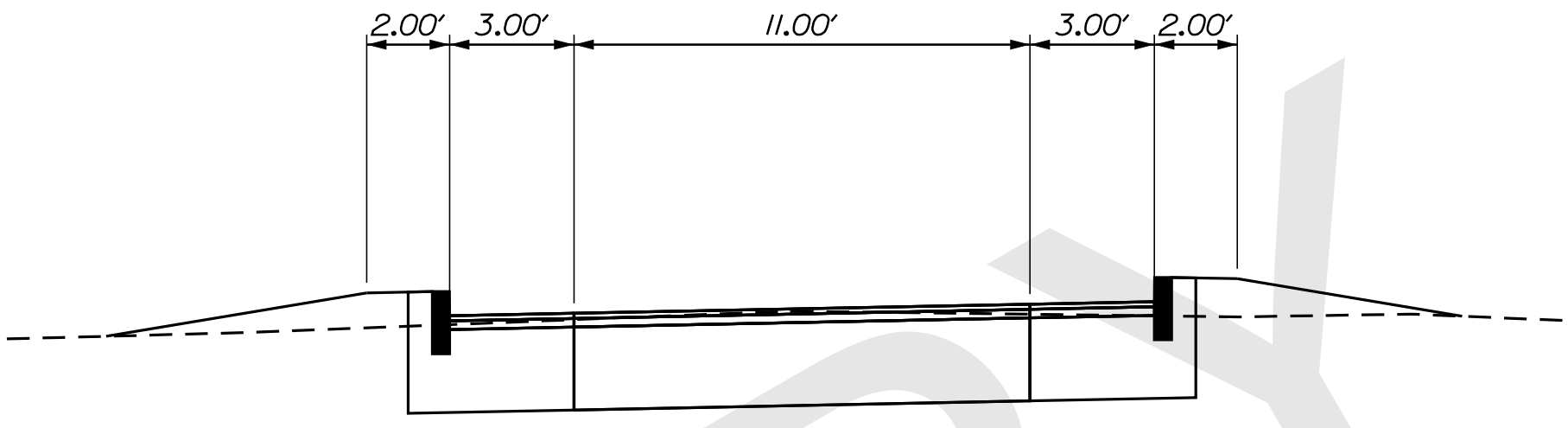

MARTIN STREET

11' TRAVELWAY
STATION TO STATION

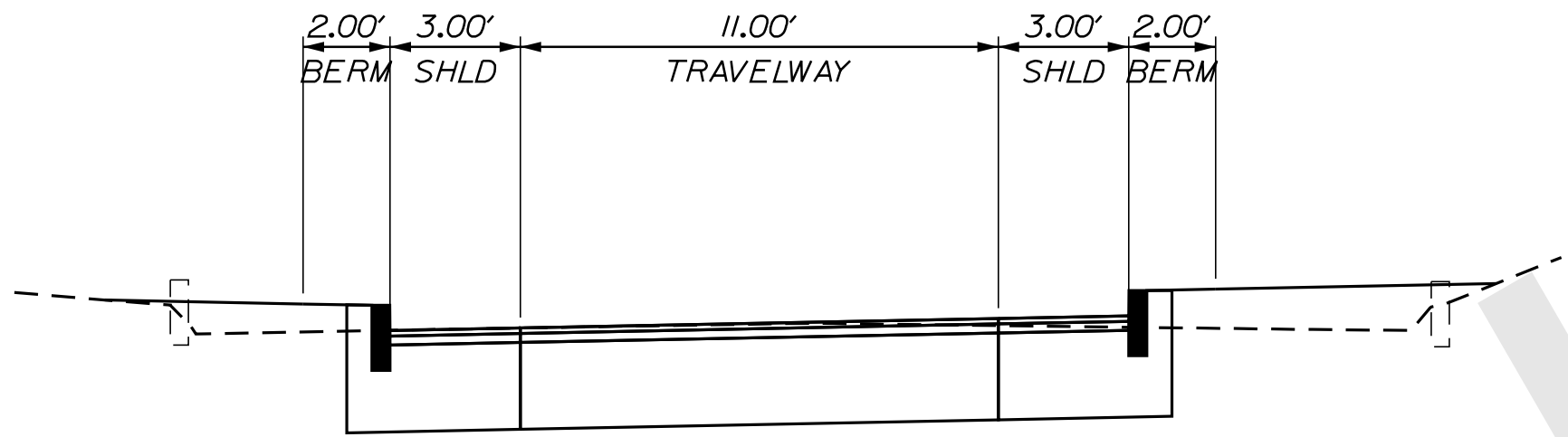

LILLIAN STREET

11' TRAVELWAY
STATION TO STATION

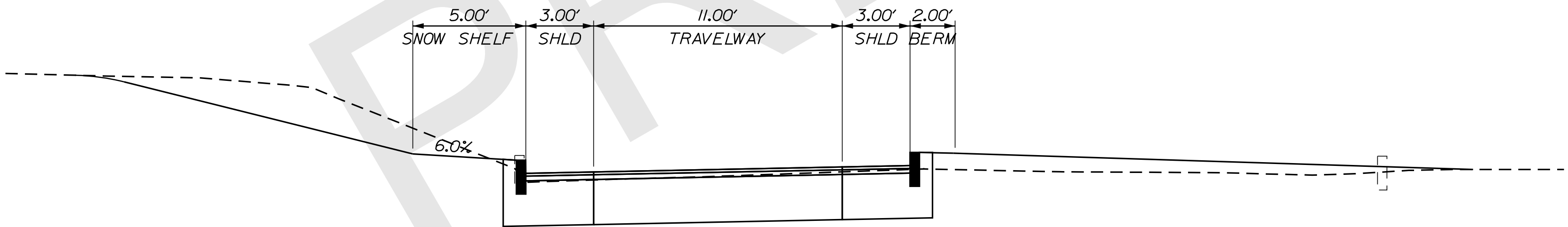

TURNER STREET

11' TRAVELWAY
STATION TO STATION

STATE OF MAINE
DEPARTMENT OF TRANSPORTATION

WIN
WIN WIN 021766.00 HIGHWAY PLANS

PROJ. MANAGER	DESIGN-DETAILED	CHECKED-REVIEWED	DESIGN-DETAILED	REVISIONS 1	REVISIONS 2	REVISIONS 3	REVISIONS 4	FIELD CHANGES
BY	DATE	SIGNATURE	P.E. NUMBER	DATE				

AUBURN
ROUTE 4
TYPICAL SECTIONS

SHEET NUMBER

©SHEET

NOT TO SCALE OF _

Filename: ... \HIGHWAY\MSTA\004_Typical3.dgn Division: HIGHWAY Username: clark.e.sullivan Date: 11/18/2019

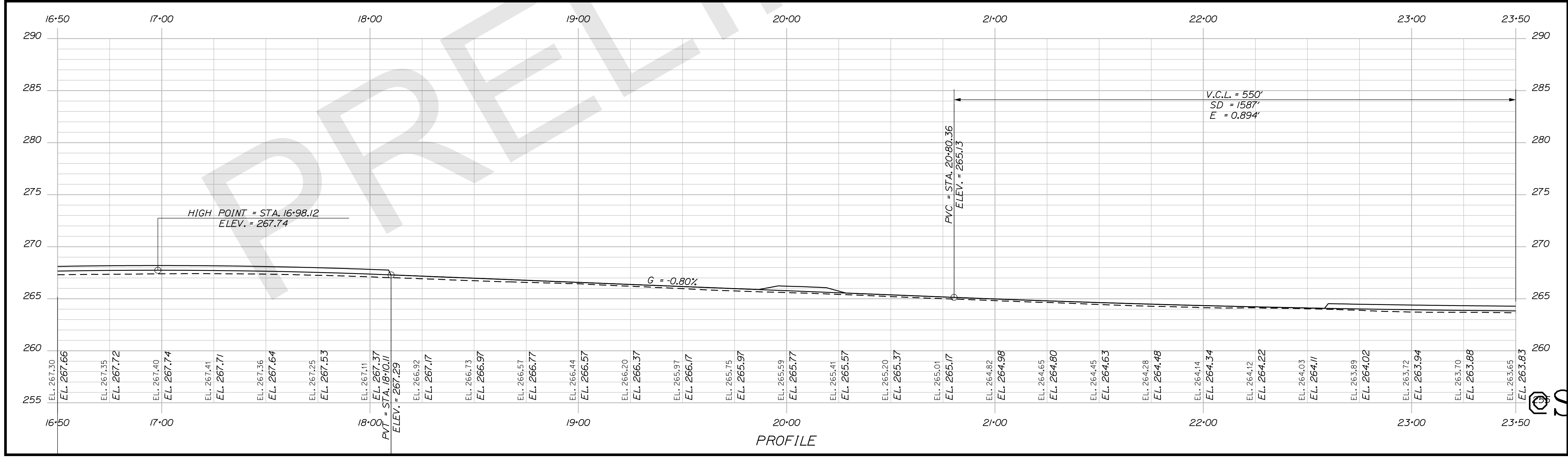
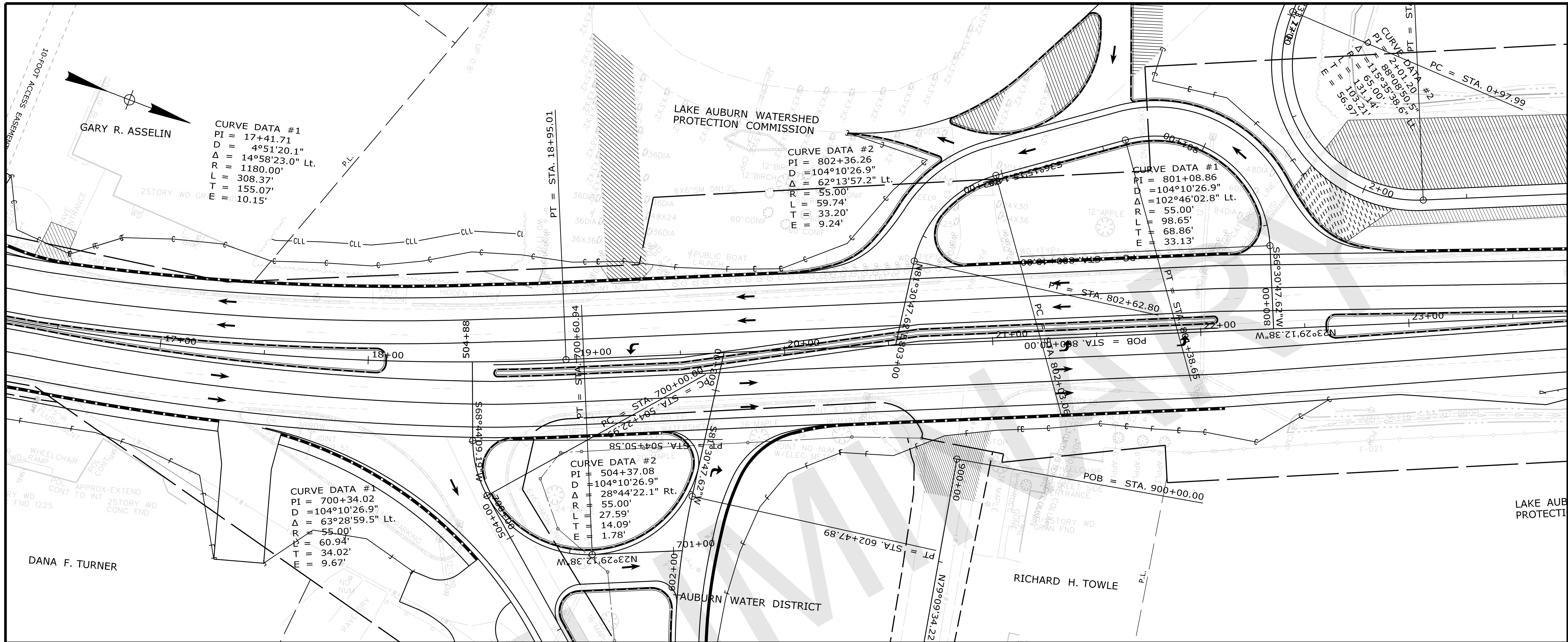

STATE OF MAINE
DEPARTMENT OF TRANSPORTATION

PROJ. MANAGER	BY	DATE
DESIGN-DETAILED	DESIGNER	DATE
CHECKED-REVIEWED	CHECKER	DATE
DESIGN-DET. APPROVED	DESIGNER	DATE
DESIGN-DET. APPROVED	DESIGNER	DATE
REVISIONS 1	REVISION	DATE
REVISIONS 2	REVISION	DATE
REVISIONS 3	REVISION	DATE
REVISIONS 4	REVISION	DATE
FIELD CHANGES	FIELD CHANGES	DATE

AUBURN
ROUTE 4
PLANS

SHEET NUMBER
OF



Filename: ... \009_HDPLAN_OakHillRoad&TurnerStreets.dwg User: clark.e.sullivan Date: 11/18/2019

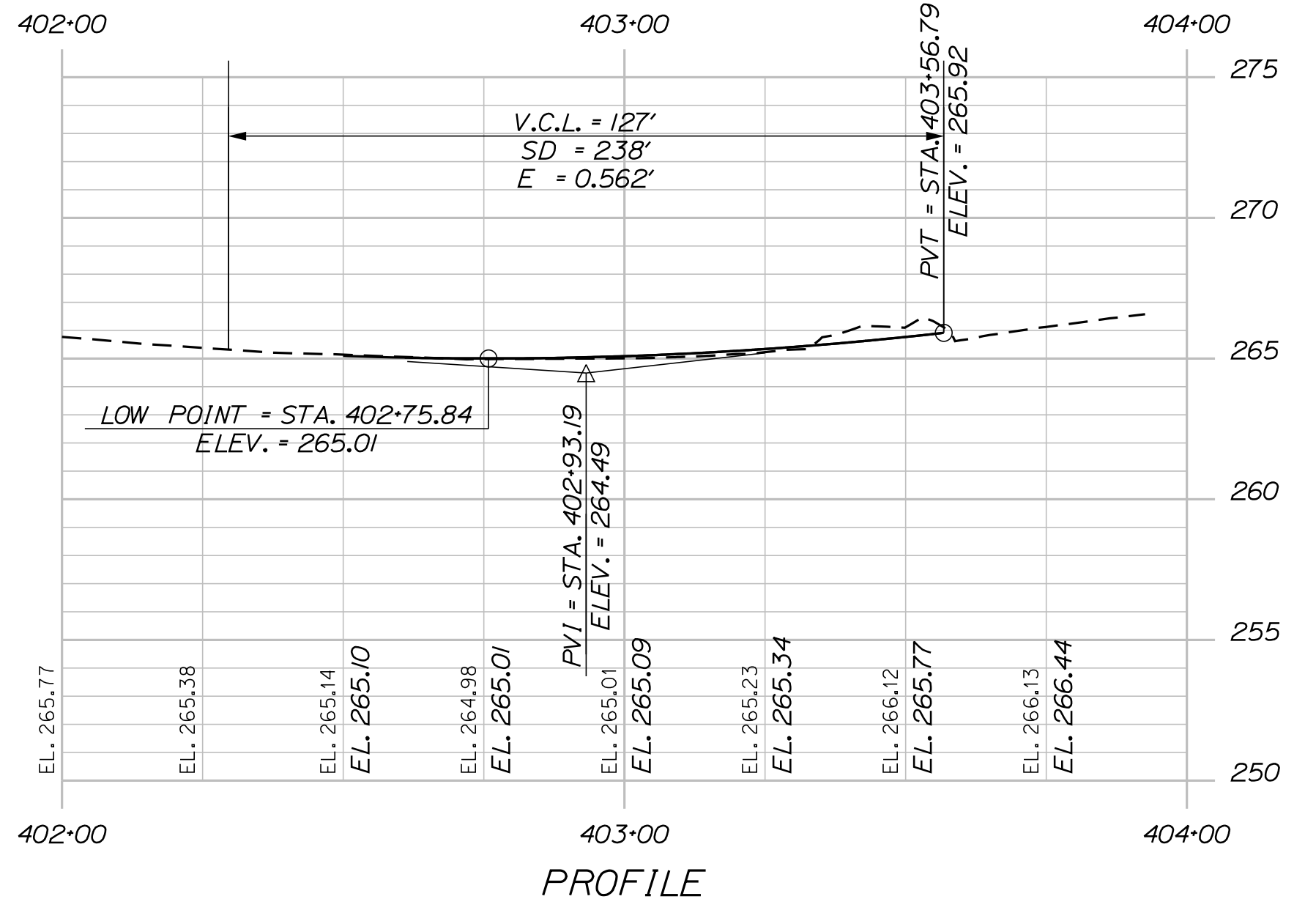
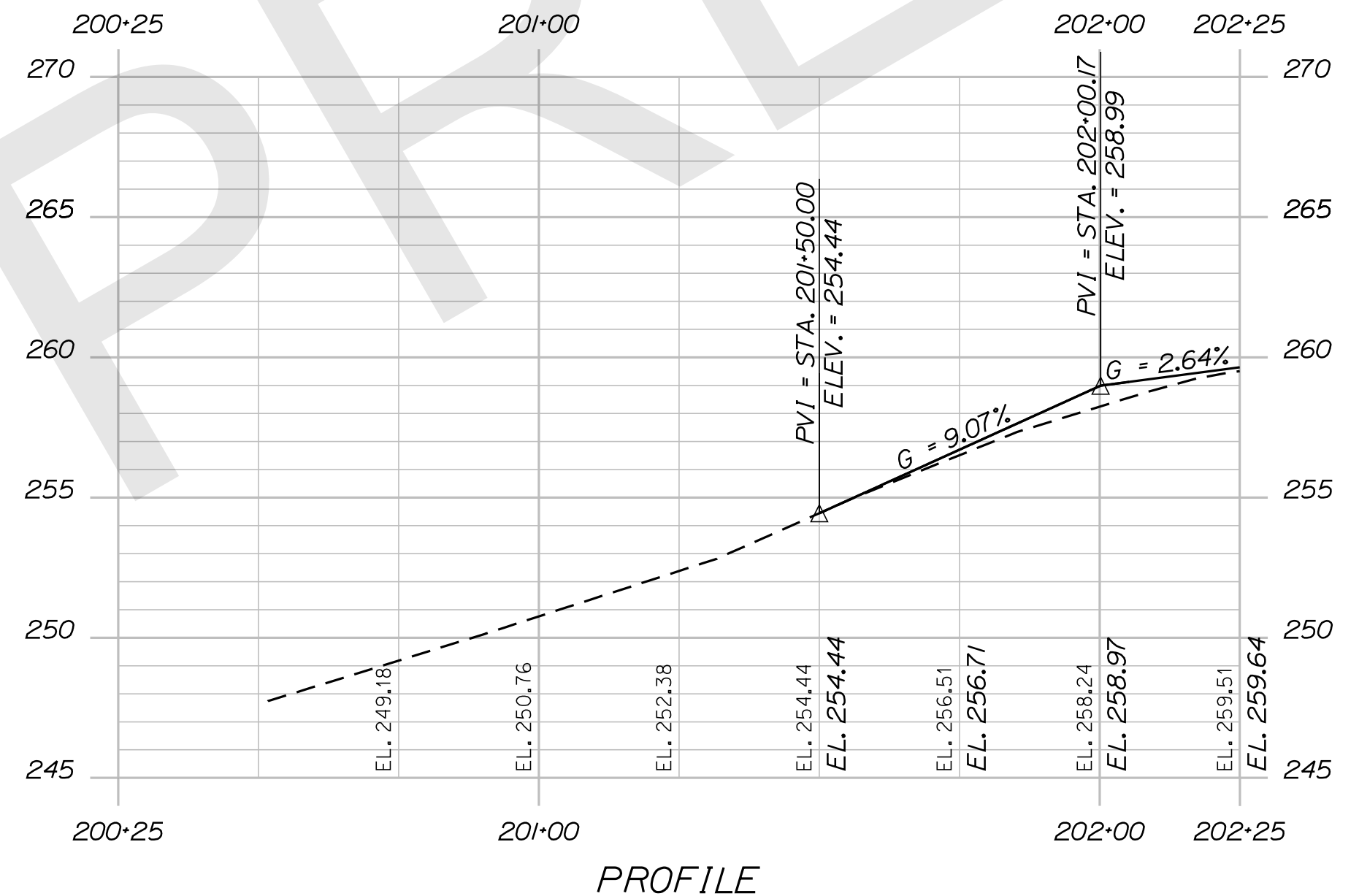
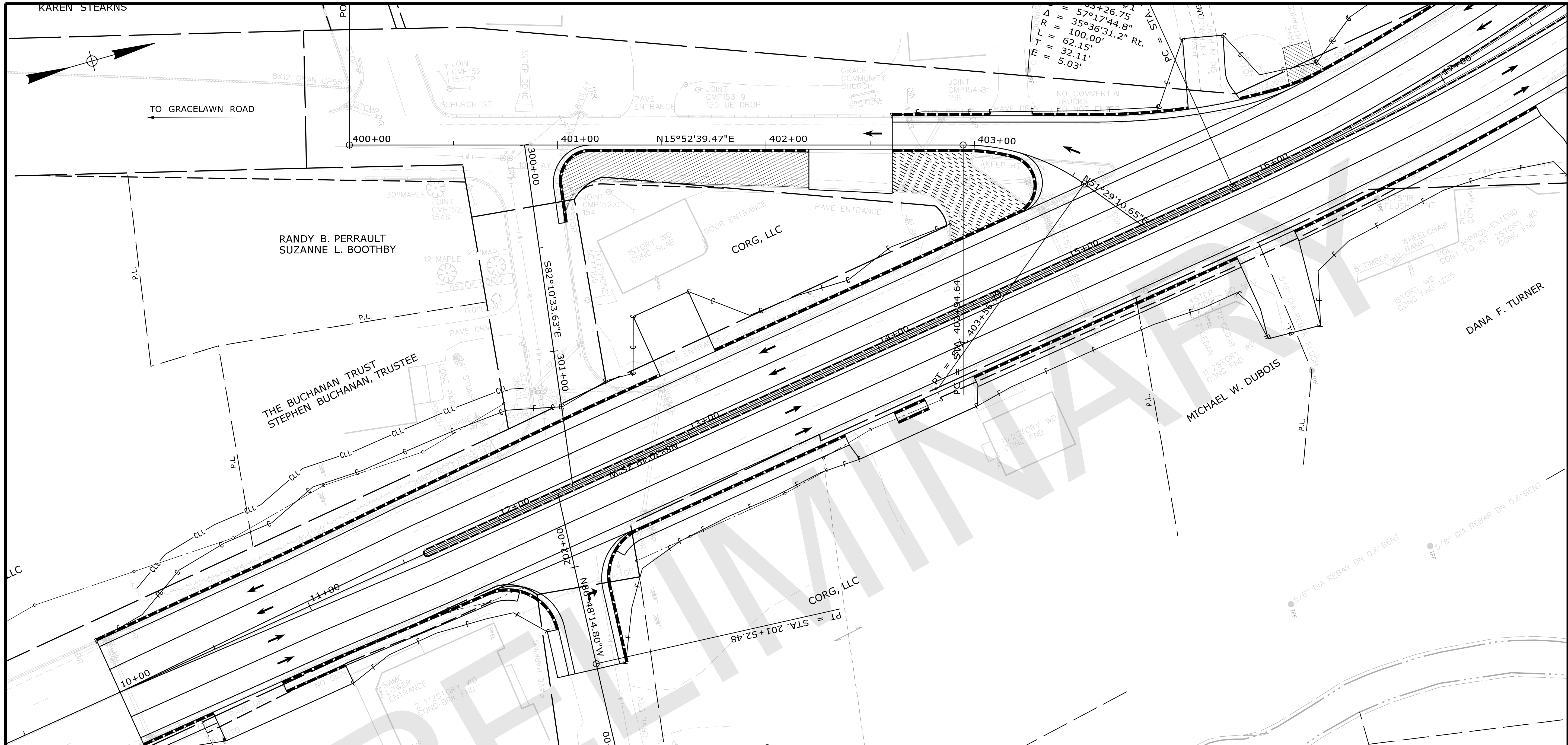

STATE OF MAINE DEPARTMENT OF TRANSPORTATION		WIN WIN WIN 021766.00 HIGHWAY PLANS																																			
AUBURN TURNER/LILLIAN STREETS		PLANS																																			
SHEET NUMBER		OF _																																			
<table border="1" style="width: 100%; border-collapse: collapse;"> <thead> <tr> <th>PROJ. MANAGER</th> <th>BY</th> <th>DATE</th> </tr> </thead> <tbody> <tr> <td>DESIGN-DETAILED</td> <td>DESIGNER</td> <td>DATE</td> </tr> <tr> <td>CHECKED-REVIEWED</td> <td>DRAWER</td> <td>DATE</td> </tr> <tr> <td>DESIGN-DETAILED</td> <td>DESIGNER</td> <td>DATE</td> </tr> <tr> <td>DESIGN-DETAILED</td> <td>DESIGNER</td> <td>DATE</td> </tr> <tr> <td>REVISIONS 1</td> <td>DATE</td> <td>DESCRIPTION</td> </tr> <tr> <td>REVISIONS 2</td> <td>DATE</td> <td>DESCRIPTION</td> </tr> <tr> <td>REVISIONS 3</td> <td>DATE</td> <td>DESCRIPTION</td> </tr> <tr> <td>REVISIONS 4</td> <td>DATE</td> <td>DESCRIPTION</td> </tr> <tr> <td>FIELD CHANGES</td> <td>DATE</td> <td>DESCRIPTION</td> </tr> </tbody> </table>	PROJ. MANAGER	BY	DATE	DESIGN-DETAILED	DESIGNER	DATE	CHECKED-REVIEWED	DRAWER	DATE	DESIGN-DETAILED	DESIGNER	DATE	DESIGN-DETAILED	DESIGNER	DATE	REVISIONS 1	DATE	DESCRIPTION	REVISIONS 2	DATE	DESCRIPTION	REVISIONS 3	DATE	DESCRIPTION	REVISIONS 4	DATE	DESCRIPTION	FIELD CHANGES	DATE	DESCRIPTION	<table border="1" style="width: 100%; border-collapse: collapse;"> <thead> <tr> <th>SIGNATURE</th> <th>P.E. NUMBER</th> <th>DATE</th> </tr> </thead> <tbody> <tr> <td> </td> <td> </td> <td> </td> </tr> </tbody> </table>	SIGNATURE	P.E. NUMBER	DATE			
PROJ. MANAGER	BY	DATE																																			
DESIGN-DETAILED	DESIGNER	DATE																																			
CHECKED-REVIEWED	DRAWER	DATE																																			
DESIGN-DETAILED	DESIGNER	DATE																																			
DESIGN-DETAILED	DESIGNER	DATE																																			
REVISIONS 1	DATE	DESCRIPTION																																			
REVISIONS 2	DATE	DESCRIPTION																																			
REVISIONS 3	DATE	DESCRIPTION																																			
REVISIONS 4	DATE	DESCRIPTION																																			
FIELD CHANGES	DATE	DESCRIPTION																																			
SIGNATURE	P.E. NUMBER	DATE																																			

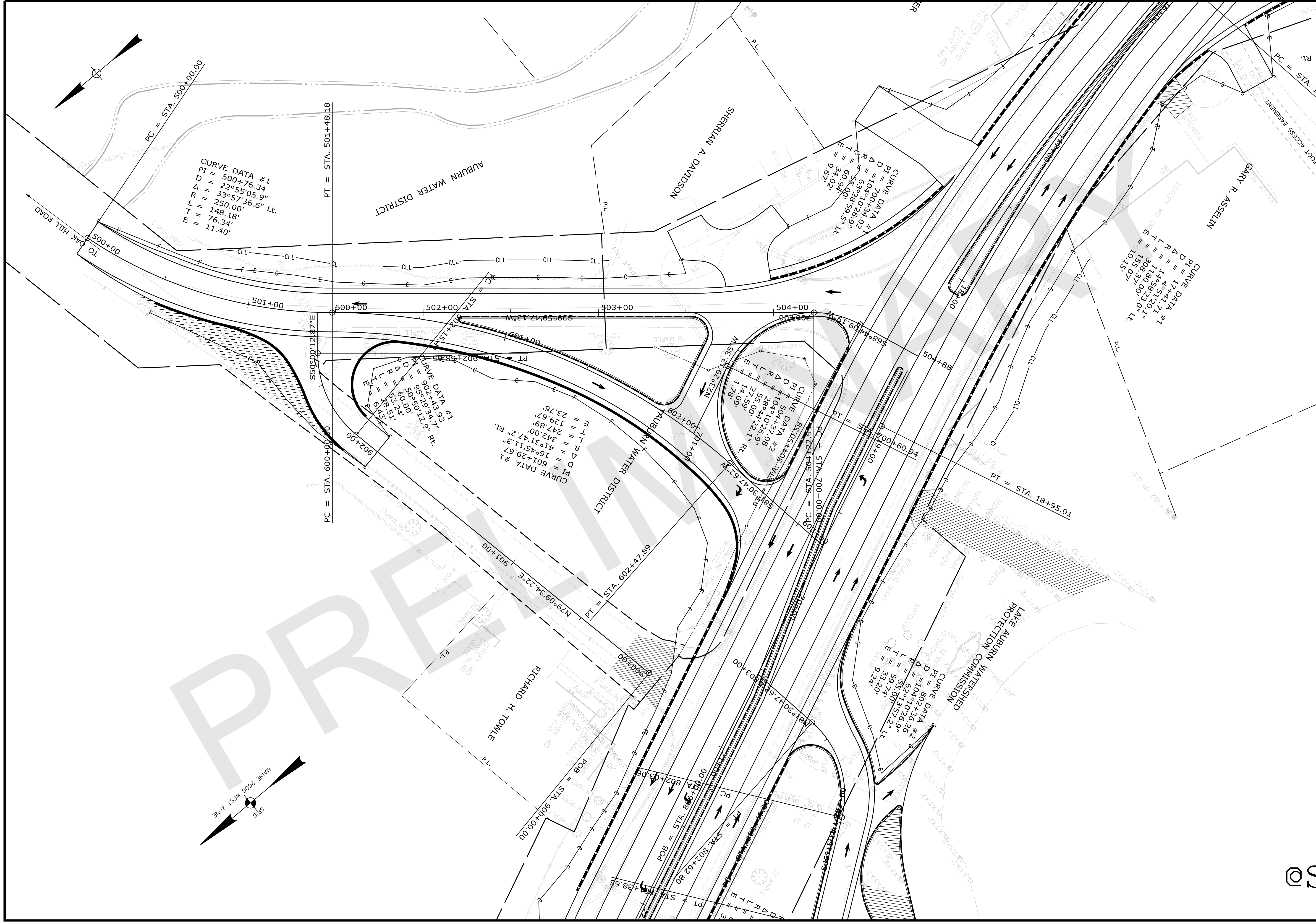

STATE OF MAINE
 DEPARTMENT OF TRANSPORTATION

PROJ. MANAGER	PROJ. MANAGER'S	BY	DATE
DESIGN-DETAILED	Designer1\$	Designer1\$	11/18/2019
CHECKED-REVIEWED	Designer2\$	Designer2\$	11/18/2019
DESIGN-DET-PAID	Designer3\$	Designer3\$	11/18/2019
DESIGN-DET-PAID2	Designer4\$	Designer4\$	11/18/2019
REVISIONS 1	Designer1\$	Designer1\$	11/18/2019
REVISIONS 2	Designer1\$	Designer1\$	11/18/2019
REVISIONS 3	Designer1\$	Designer1\$	11/18/2019
REVISIONS 4	Designer1\$	Designer1\$	11/18/2019
FIELD CHANGES	FieldChange1\$	FieldChange1\$	11/18/2019

AUBURN
 MARTIN ST./E. JUG HANDLE
 PLANS

SHEET NUMBER
 OF 1



WIN WIN 021766.00 HIGHWAY PLANS

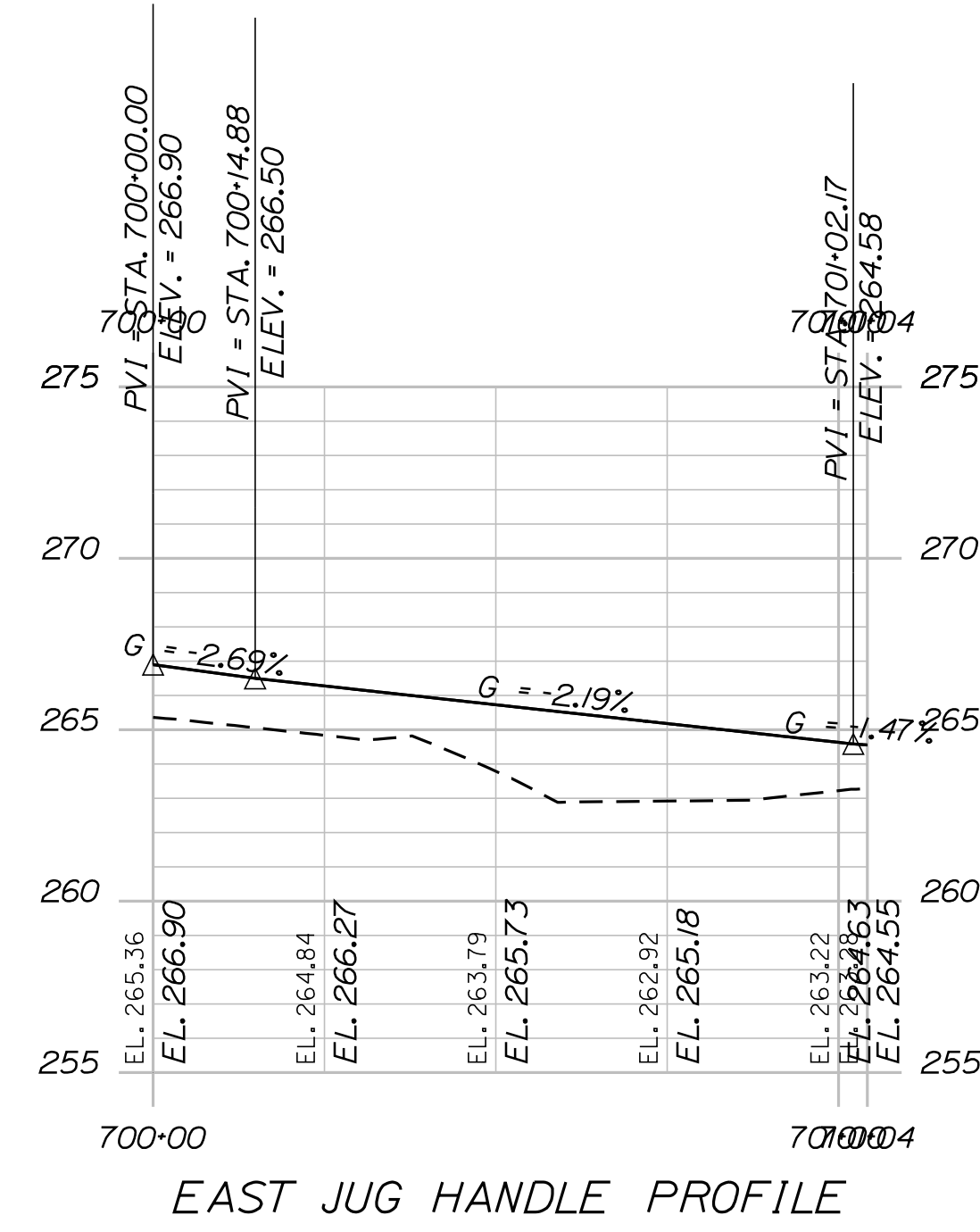
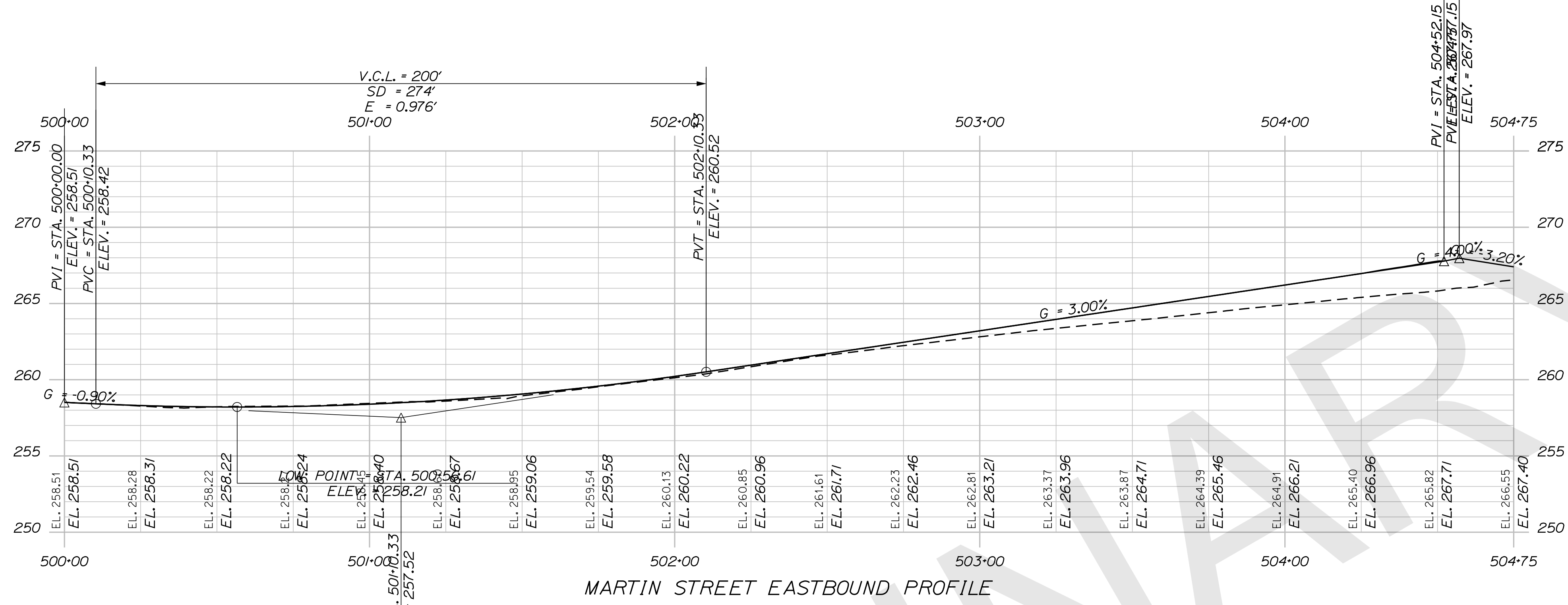
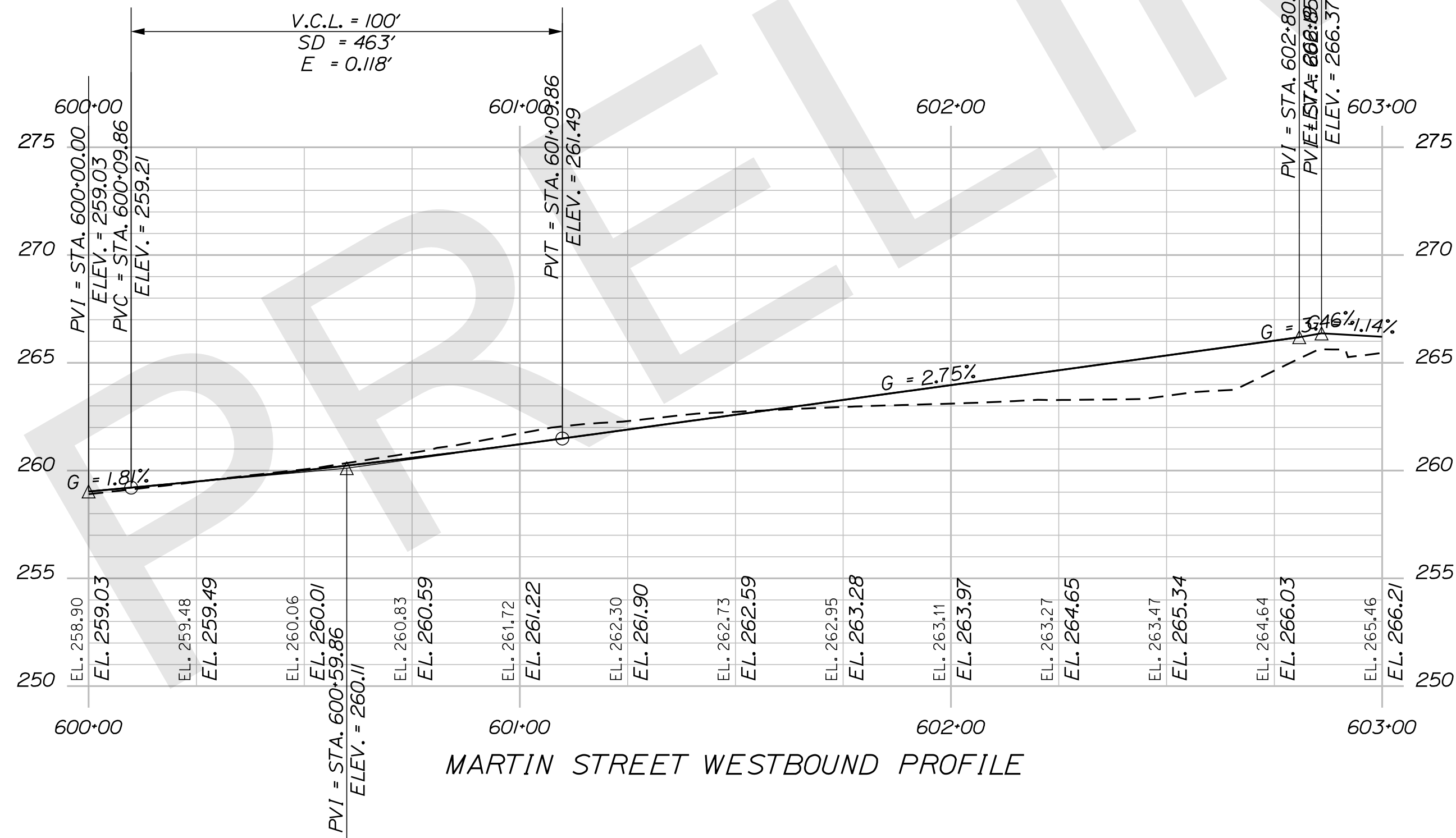

STATE OF MAINE

DEPARTMENT OF TRANSPORTATION

SIGNATURE

P.E. NUMBER

DATE

DATE

BY

PROJ. MANAGER

DESIGN DETAILER

CHECKED

DESIGN DETAILER

DESIGN DETAILER

REVISIONS 1

REVISIONS 2

REVISIONS 3

REVISIONS 4

FIELD CHANGES

DATE

DATE

DATE

DATE

DATE

DATE

DATE

DATE

DATE

DATE

DATE

DATE

DATE

DATE

DATE

STATE OF MAINE
DEPARTMENT OF TRANSPORTATION

SIGNATURE
P.E. NUMBER
DATE

BY
PROJ. MANAGER
DESIGN DETAILER
CHECKED
DESIGN DETAILER
DESIGN DETAILER
REVISIONS 1
REVISIONS 2
REVISIONS 3
REVISIONS 4
FIELD CHANGES

AUBURN
MARTIN ST./E. JUG HANDLE
PLANS

SHEET NUMBER

OSHEET

OF

WIN WIN 021766.00 HIGHWAY PLANS

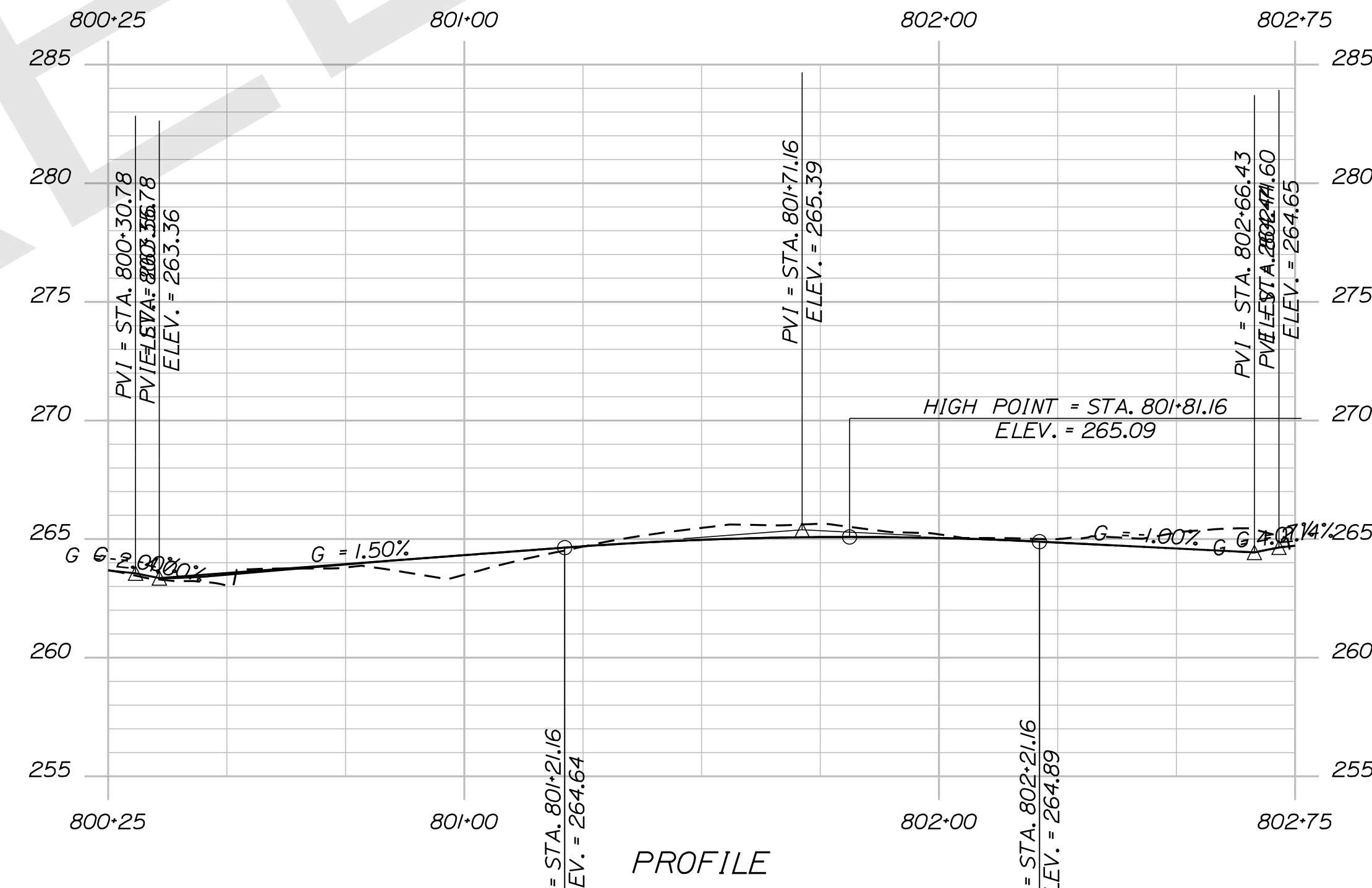
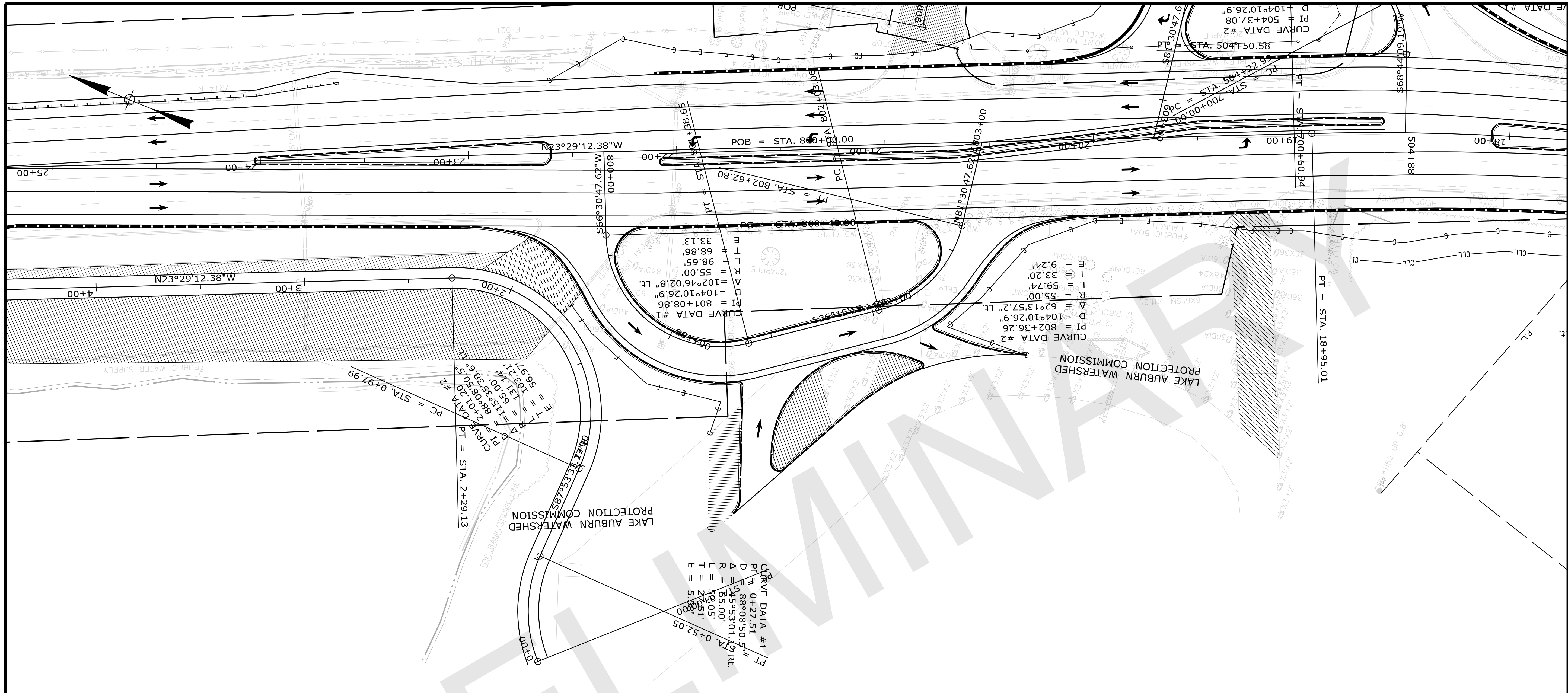

STATE OF MAINE
DEPARTMENT OF TRANSPORTATION

PROJ. MANAGER	PROJ. MANAGER'S	BY	DATE
DESIGN-DETAILED	DESIGNER'S	DATE	DATE
CHECKED-REVIEWED	DESIGNER'S	DATE	DATE
DESIGNS DET. TAILED	DESIGNER'S	DATE	DATE
DESIGNS DET. TAILED	DESIGNER'S	DATE	DATE
REVISIONS 1	DESIGNER'S	DATE	DATE
REVISIONS 2	DESIGNER'S	DATE	DATE
REVISIONS 3	DESIGNER'S	DATE	DATE
REVISIONS 4	DESIGNER'S	DATE	DATE
FIELD CHANGES	DESIGNER'S	DATE	DATE

AUBURN
ROUTE 4
PLANS

SHEET NUMBER
OF _



WIN WIN 021766.00 HIGHWAY PLANS

Date: 11/18/2019

Username: clark.e.salloway

Division: HIGHWAY

Filename: ... \MSTA013_XSECT_9+75_001.dgn

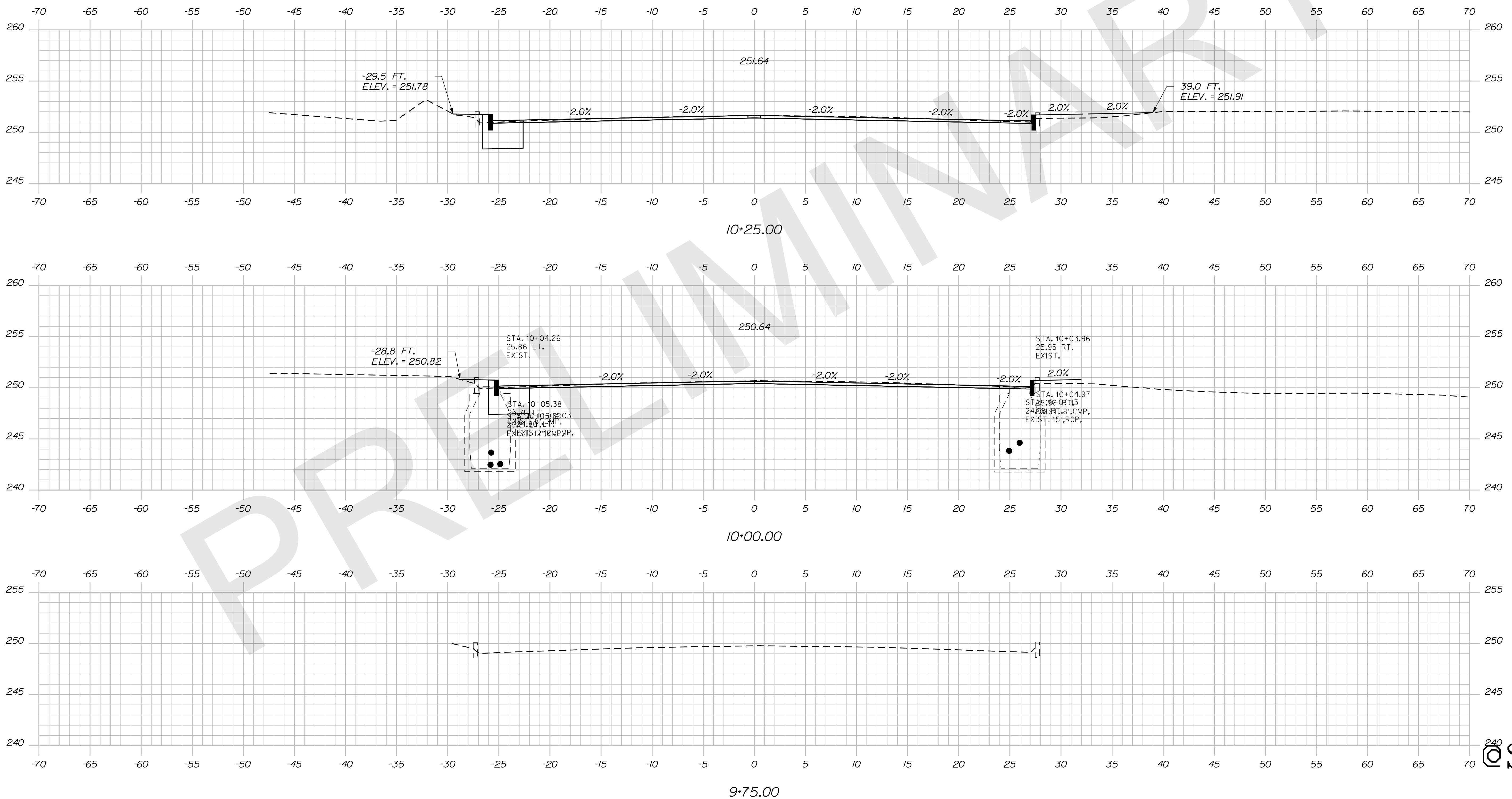

STATE OF MAINE
 DEPARTMENT OF TRANSPORTATION

SIGNATURE _____
 P.E. NUMBER _____
 DATE _____

PROJ. MANAGER	DESIGNER	CHECKER	DATE

AUBURN
 ROUTE 4
 CROSS SECTIONS

SHEET NUMBER
 240
 OF 240

Date: 11/18/2019

Username: clark.e.sullivan

Division: HIGHWAY

Filename: ... \MSTAO14_XSECT_10+50_002.dgn

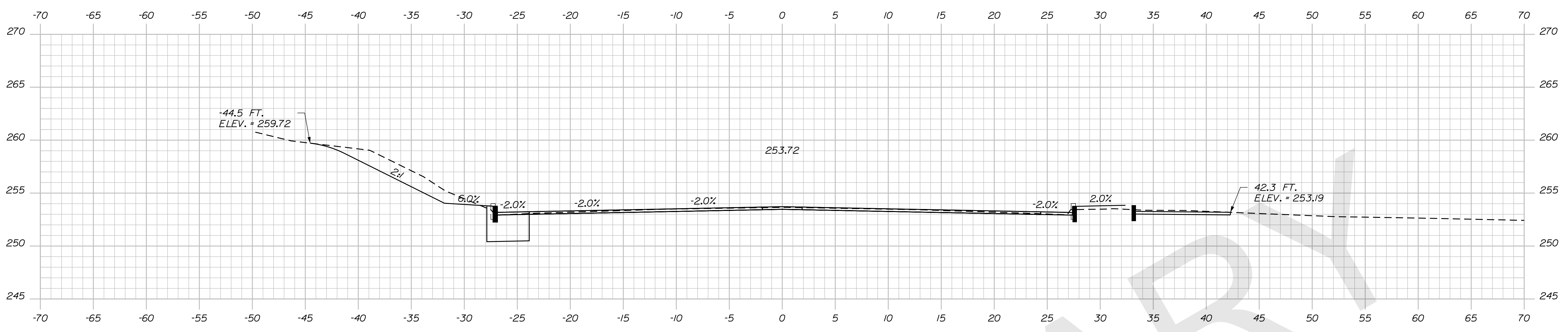

10+75.00

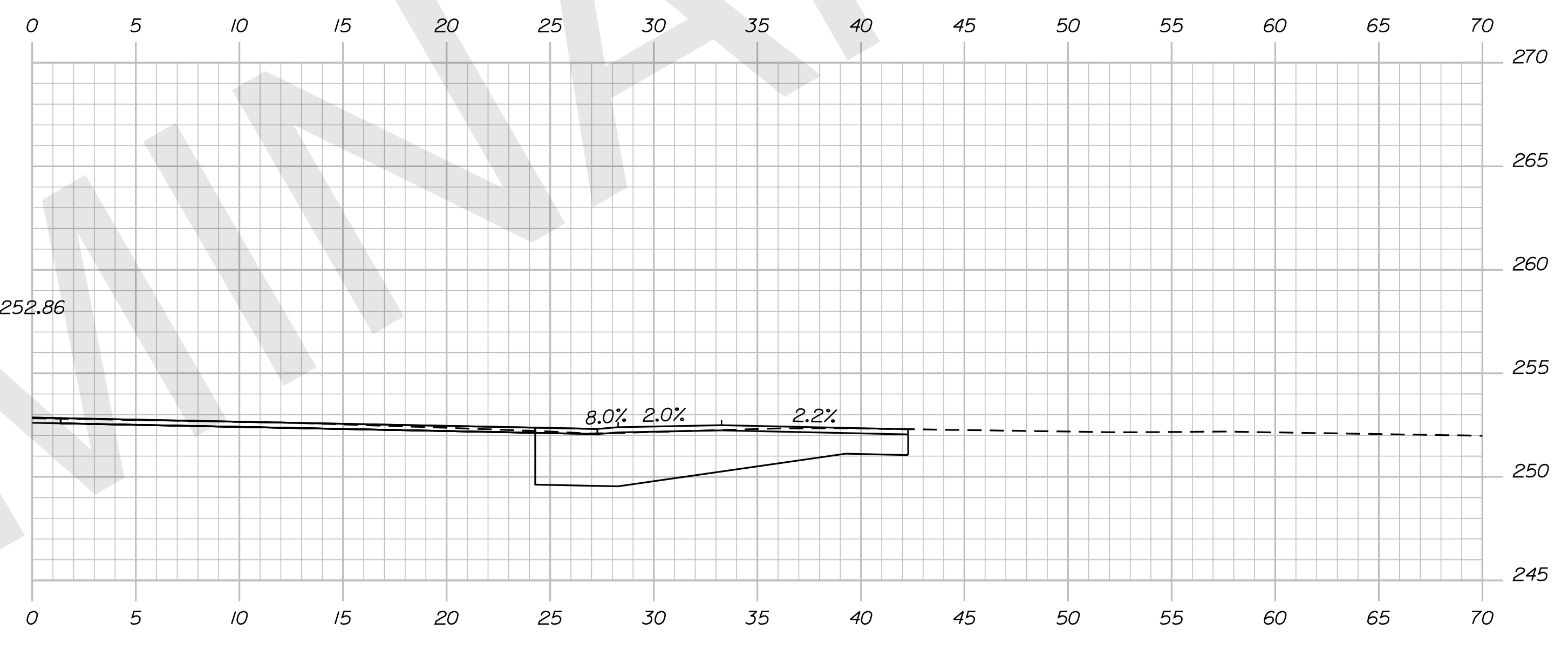

10+55.00

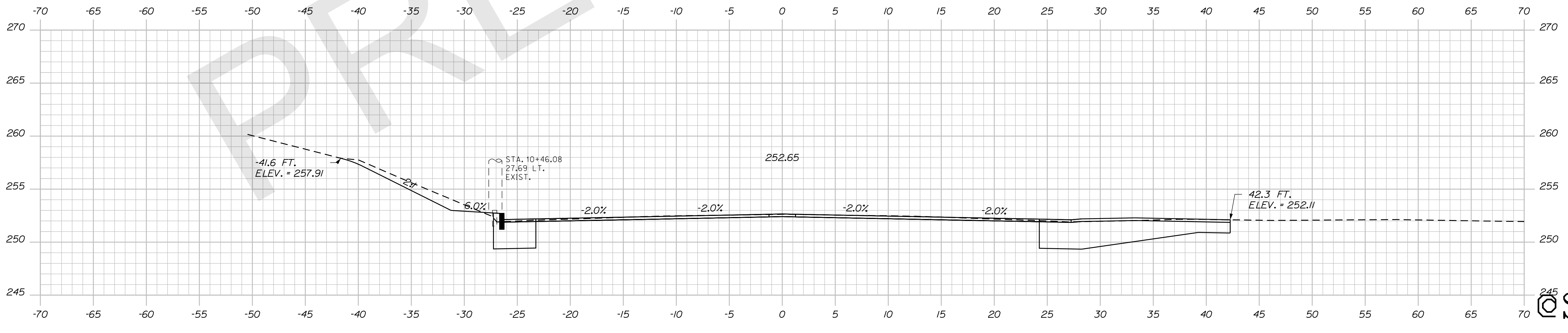

10+50.00

STATE OF MAINE
DEPARTMENT OF TRANSPORTATION

PROJ. MANAGER	BY	DATE	SIGNATURE
DESIGN-DETAILED	DESIGNER	DATE	
CHECKED-REVIEWED	CHECKER	DATE	
DESIGN-DETAILED	DESIGNER	DATE	
DESIGN-DETAILED	DESIGNER	DATE	
REVISIONS 1	DESIGNER	DATE	
REVISIONS 2	DESIGNER	DATE	
REVISIONS 3	DESIGNER	DATE	
REVISIONS 4	DESIGNER	DATE	
FIELD CHANGES	DESIGNER	DATE	

AUBURN
ROUTE 4
CROSS SECTIONS

SHEET NUMBER
OF SHEET

Sta. 10+50.00 to Sta. 10+75.00

Date: 11/18/2019

Username: clark.e.sullivan

Division: HIGHWAY

Filename: ... \MSTAD015_XSECT_11+00_003.dgn

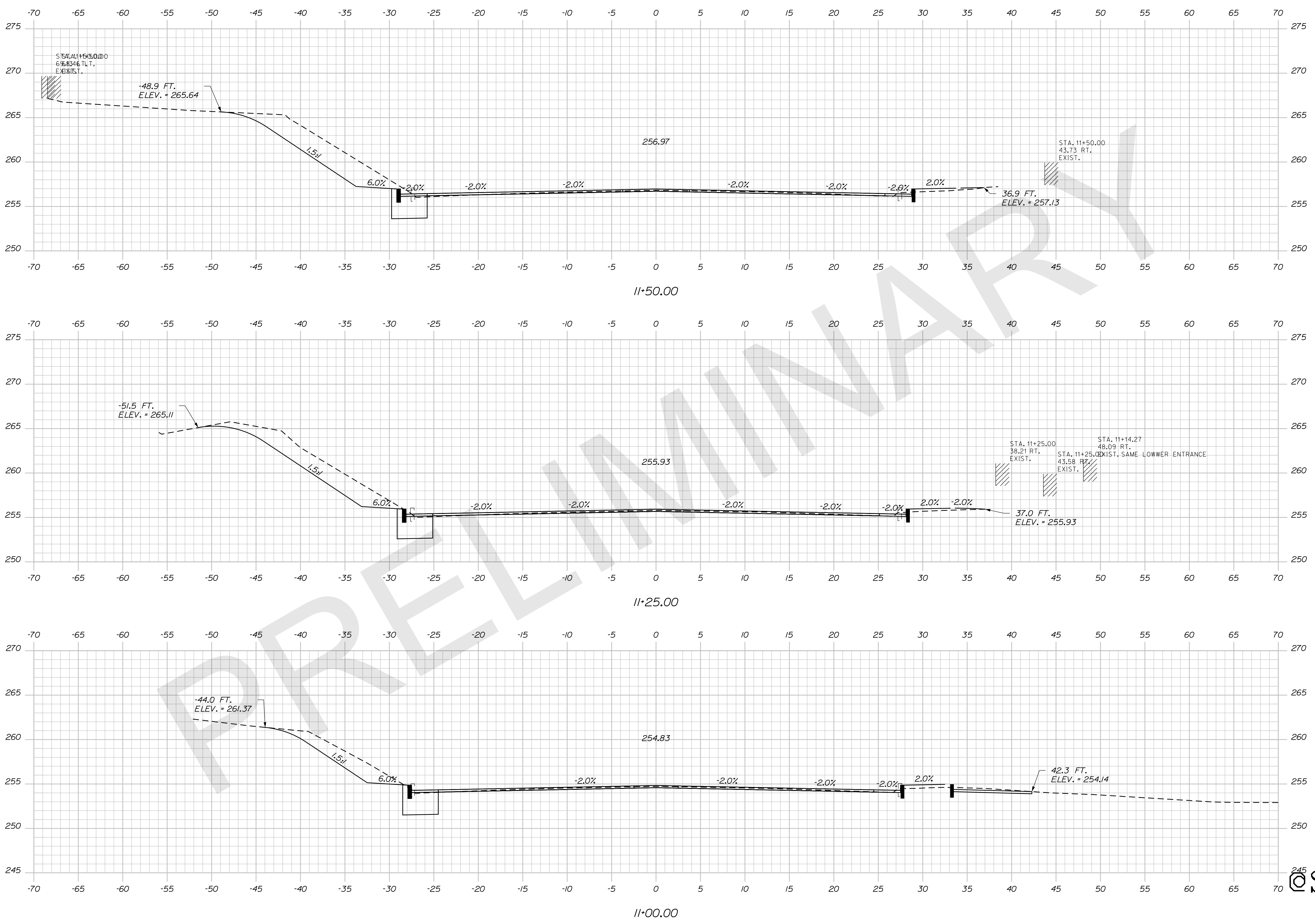

STATE OF MAINE
DEPARTMENT OF TRANSPORTATION

PROJ. MANAGER	DESIGN-DETAILED	CHECKED-REVIEWED	DESIGN-DETAILED	DESIGN-DETAILED	DESIGN-DETAILED	REVISIONS 1	REVISIONS 2	REVISIONS 3	REVISIONS 4	FIELD CHANGES	DATE	BY	DATE	SIGNATURE	P.E. NUMBER	DATE

AUBURN
ROUTE 4
CROSS SECTIONS

SHEET NUMBER
OF SHEET

Date: 11/18/2019

Username: clark.e.sullivan

Division: HIGHWAY

Filename: ... \MSTAO16_XSECT_11+75_004.dgn

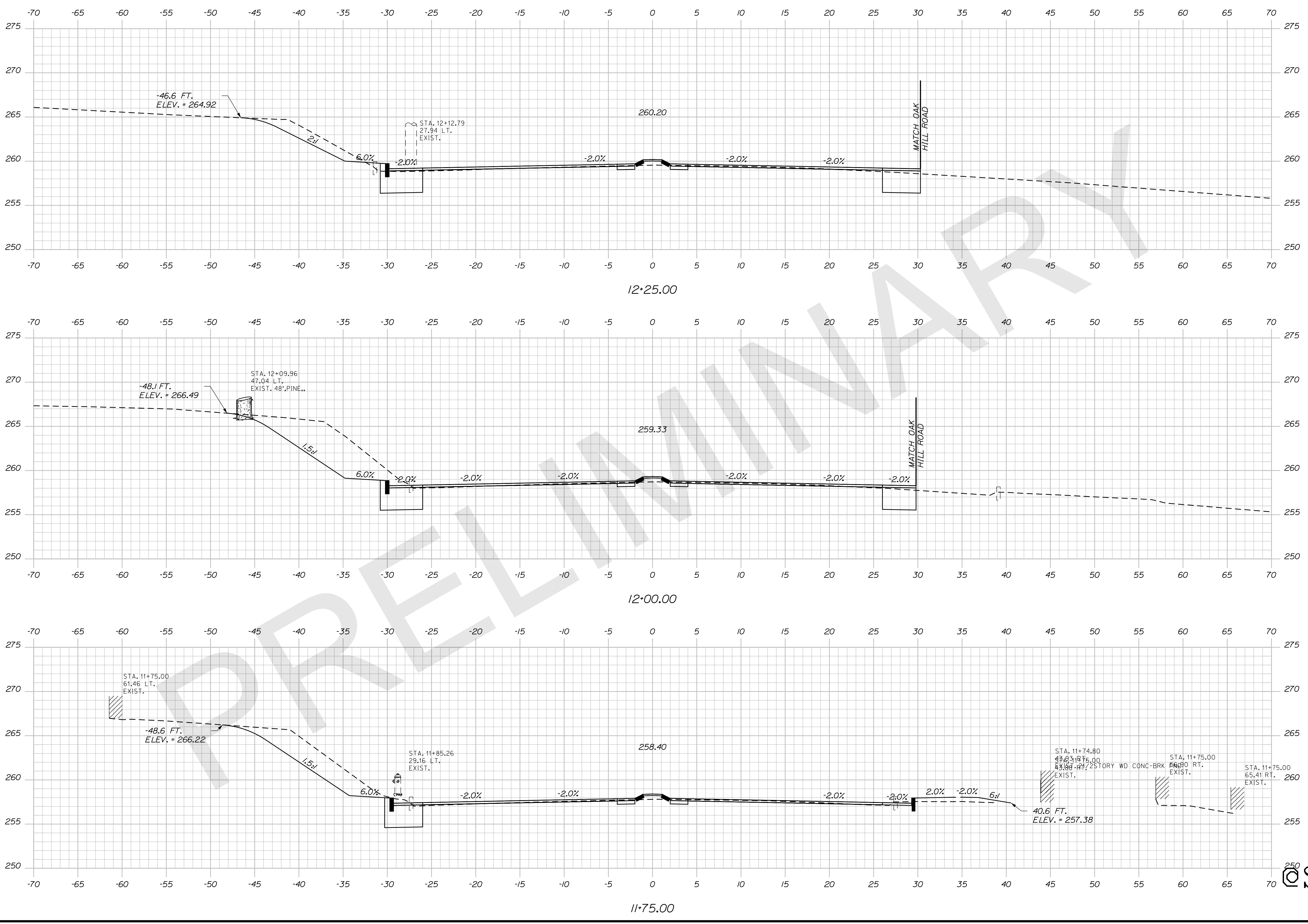

STATE OF MAINE DEPARTMENT OF TRANSPORTATION		SIGNATURE	
WIN		P.E. NUMBER	
WIN WIN 021766.00		DATE	
HIGHWAY PLANS			
AUBURN ROUTE 4		CROSS SECTIONS	
SHEET NUMBER		OF	

Date: 11/18/2019

Username: clark.e.sullivan

Division: HIGHWAY

Filename: ... \MSTA017_XSECT_12+50_005.dgn

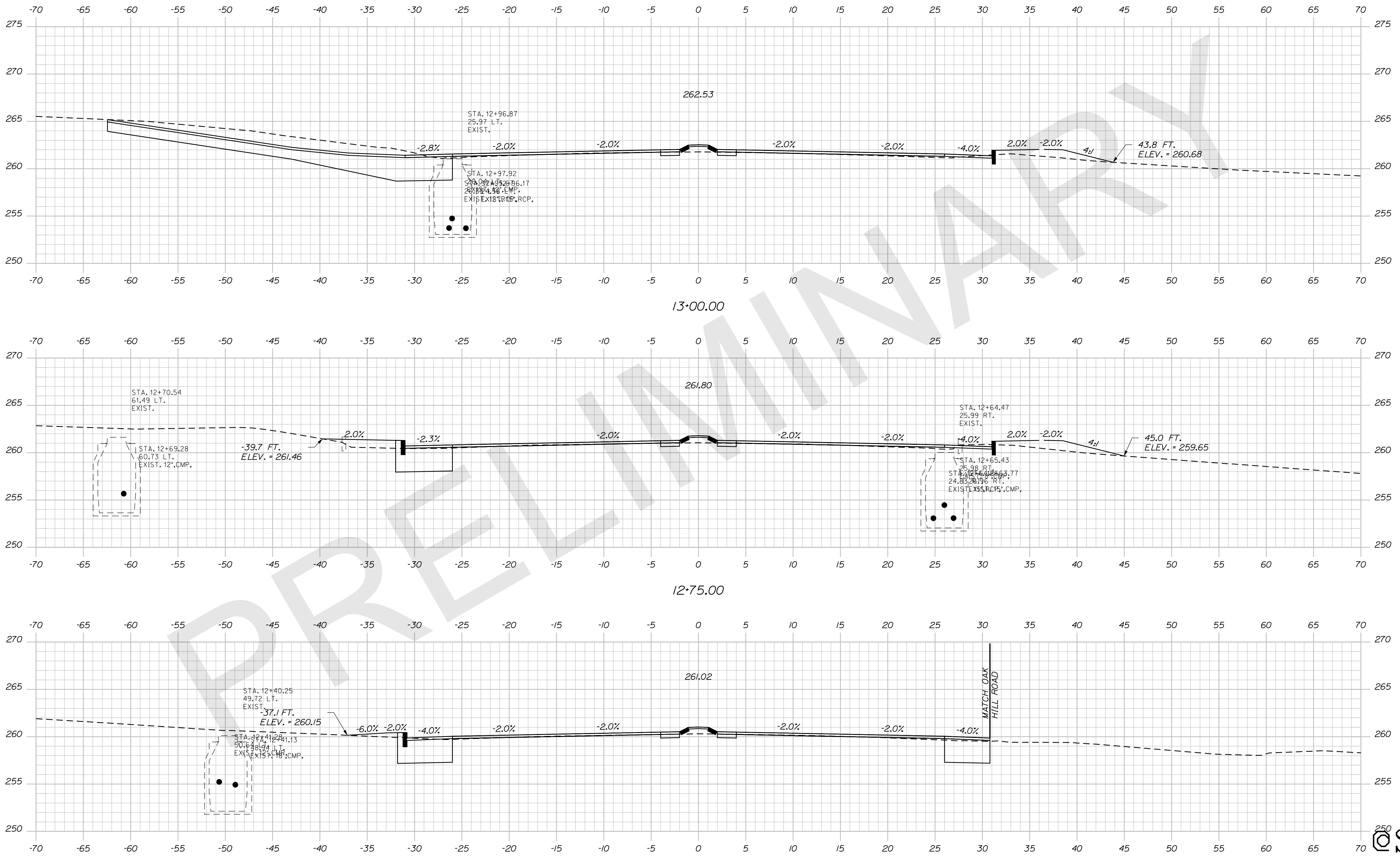

STATE OF MAINE
DEPARTMENT OF TRANSPORTATION

SIGNATURE
P.E. NUMBER
DATE

PROJ. MANAGER	DESIGN-DETAILED	CHECKED-REVIEWED	DESIGN-DETAILED	DESIGN-DETAILED	REVISIONS 1	REVISIONS 2	REVISIONS 3	REVISIONS 4	FIELD CHANGES

AUBURN
ROUTE 4
CROSS SECTIONS

SHEET NUMBER
250
OF

WIN
WIN WIN 021766.00 HIGHWAY PLANS

Date: 11/18/2019

Username: clark.e.salloway

Division: HIGHWAY

Filename: ... \MSTAD018_XSECT_13+13_006.dgn

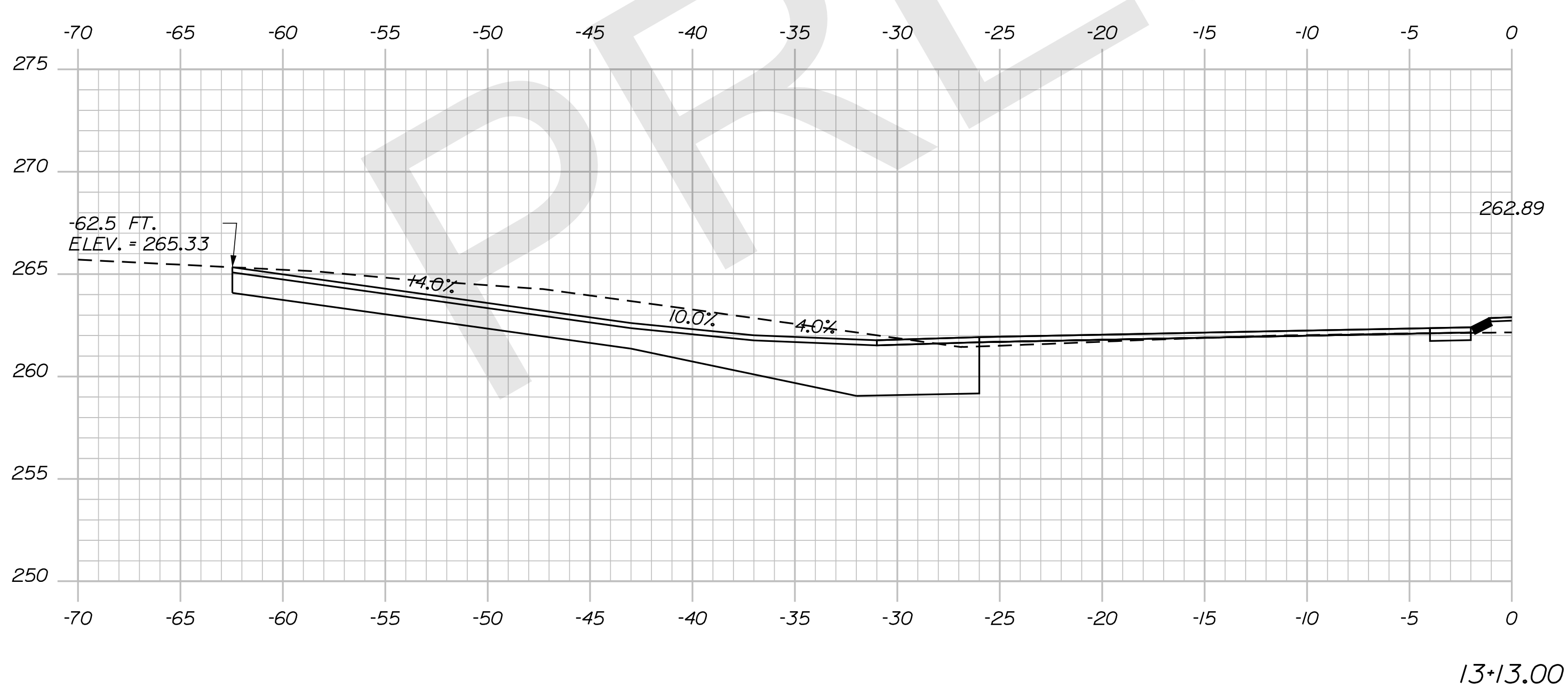
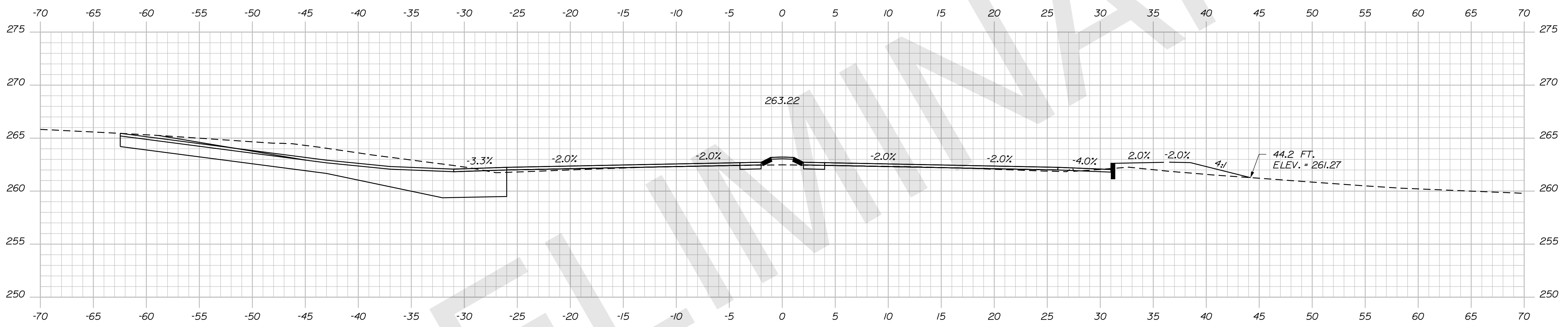
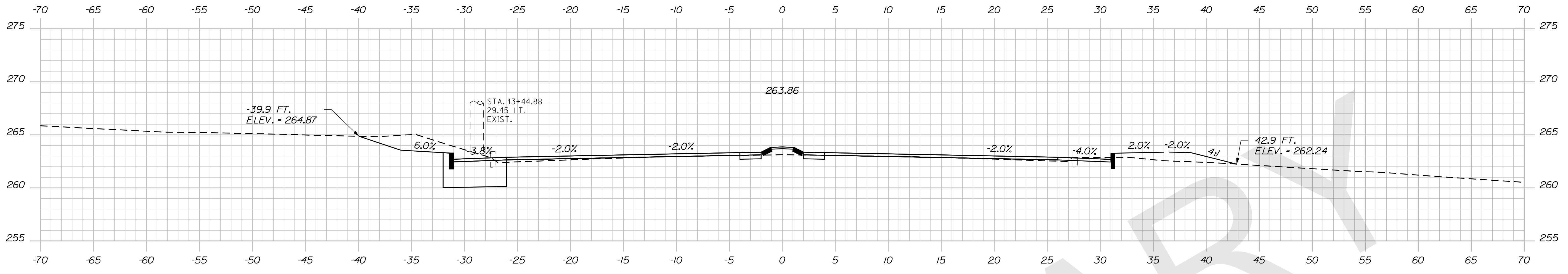

STATE OF MAINE
DEPARTMENT OF TRANSPORTATION

PROJ. MANAGER	DESIGN-DETAILED	CHECKED-REVIEWED	DESIGN-DETAILED	DESIGN-DETAILED	REVISIONS 1	REVISIONS 2	REVISIONS 3	REVISIONS 4	FIELD CHANGES
\$ProjectManager	\$Designer	\$Checker	\$Designer	\$Designer	\$Revision1	\$Revision2	\$Revision3	\$Revision4	\$FieldChanges
DATE	BY	DATE	BY	DATE	BY	DATE	BY	DATE	BY
\$ProjectDate	\$Designer	\$ProjectDate	\$Designer	\$ProjectDate	\$RevisionDate1	\$RevisionDate2	\$RevisionDate3	\$RevisionDate4	\$FieldDate
SIGNATURE					P.E. NUMBER				
DATE					DATE				

AUBURN
ROUTE 4
CROSS SECTIONS

SHEET NUMBER
OF _

©SHEET

Date: 11/18/2019

Username: clark.e.sullivan

Division: HIGHWAY

Filename: ... \MSTAD019_XSECT_13+75_007.dgn

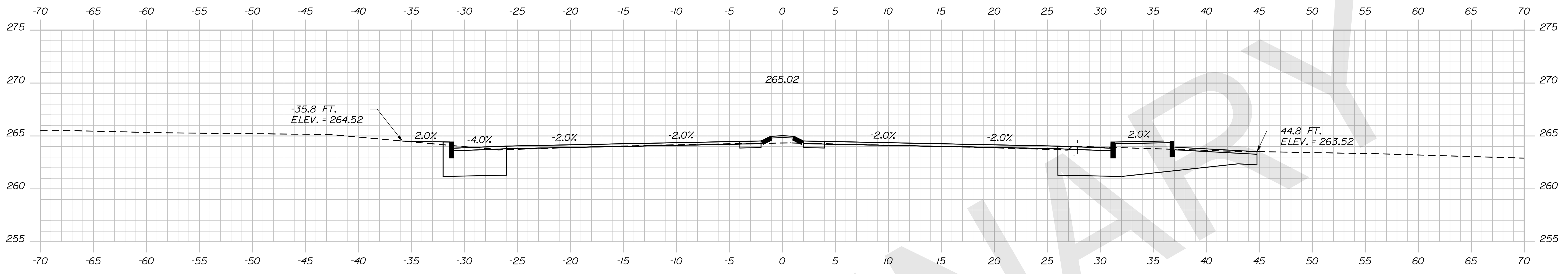

14+00.00

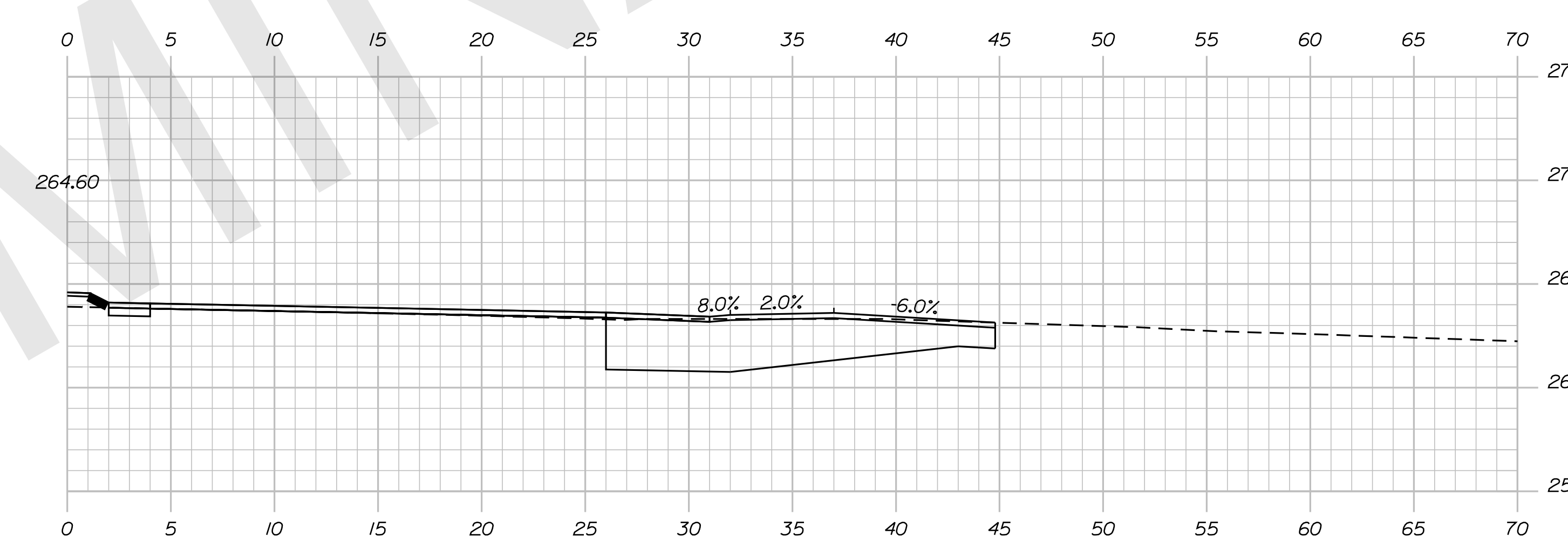

13+81.00

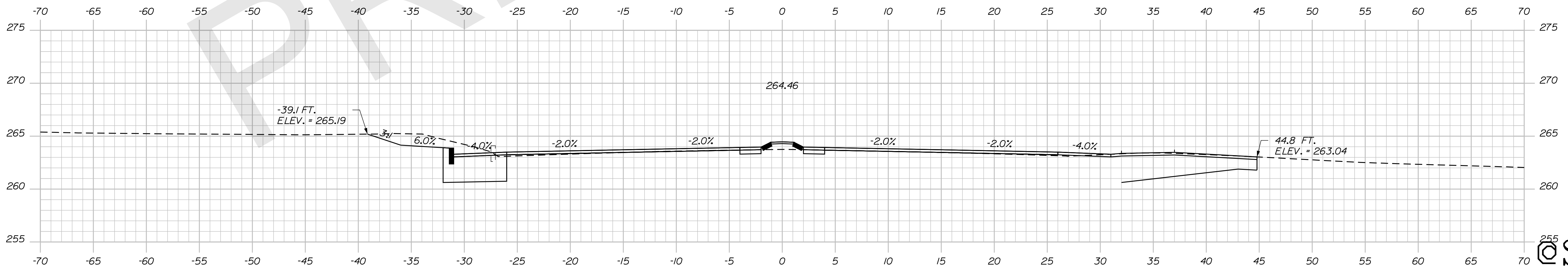

13+75.00

STATE OF MAINE
DEPARTMENT OF TRANSPORTATION

PROJ. MANAGER	BY	DATE
CHECKED-REVIEWED	DESIGNER	DATE
DESIGN DET. TAILED	DESIGNER	DATE
DESIGN DET. TAILED	DESIGNER	DATE
REVISIONS 1	DATE	
REVISIONS 2	DATE	
REVISIONS 3	DATE	
REVISIONS 4	DATE	
FIELD CHANGES	DATE	

AUBURN
ROUTE 4
CROSS SECTIONS

SHEET NUMBER
13
OF 19

WIN
WIN WIN 021766.00 HIGHWAY PLANS

Date: 11/18/2019

Username: clark.e.sullivan

Division: HIGHWAY

Filename: ... \MSTAD20_XSECT_14+25_008.dgn

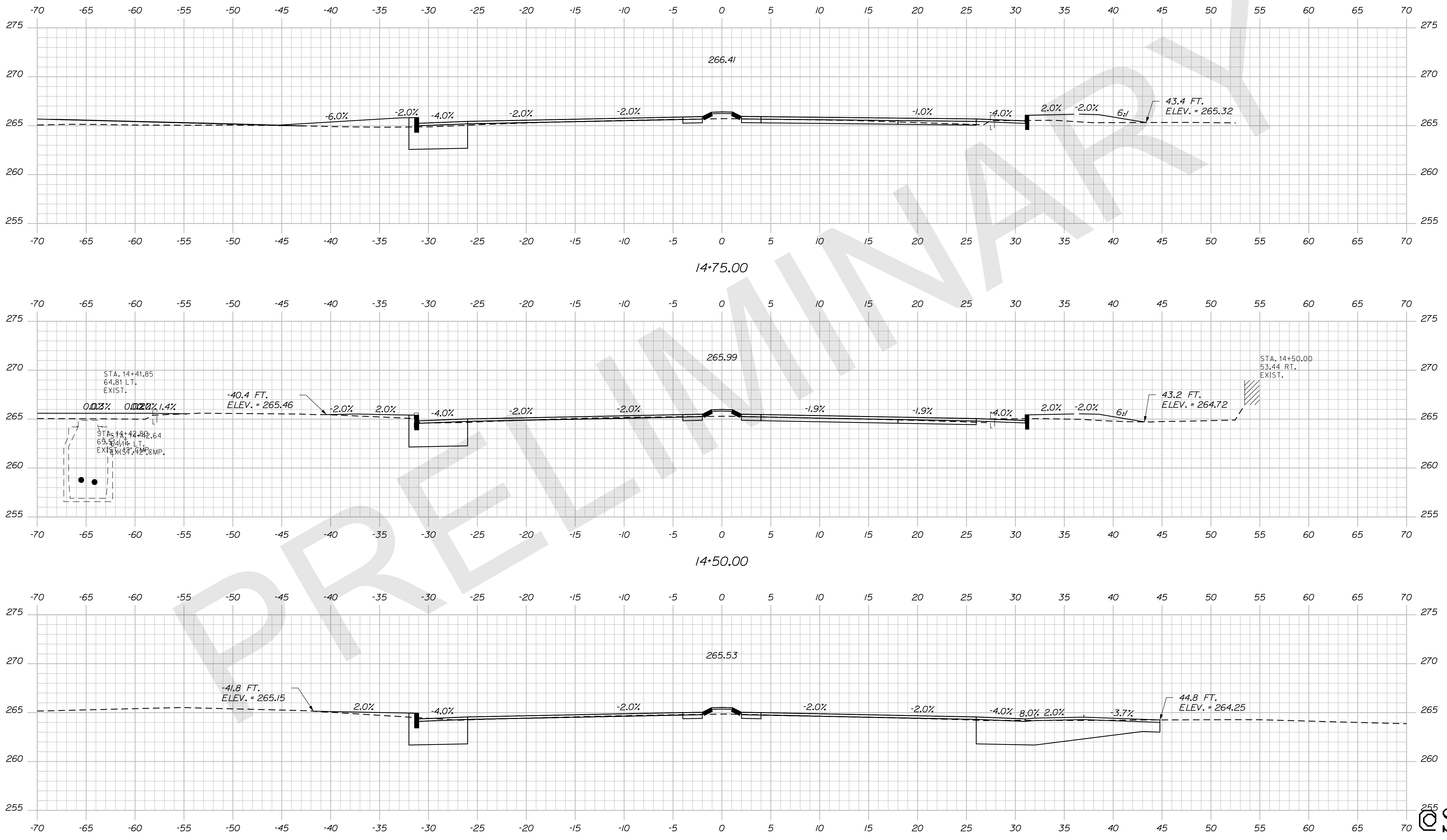

STATE OF MAINE DEPARTMENT OF TRANSPORTATION		WIN WIN WIN 021766.00 HIGHWAY PLANS
	SIGNATURE	P.E. NUMBER
	DATE	DATE
	BY	DATE
	PROJ. MANAGER	DATE
	DESIGN-REVIEWED	DATE
	DESIGN DET. TAILED	DATE
	REVISIONS 1	DATE
	REVISIONS 2	DATE
	REVISIONS 3	DATE
	REVISIONS 4	DATE
	FIELD CHANGES	DATE

AUBURN ROUTE 4

CROSS SECTIONS

SHEET NUMBER

10 SHEET

OF 1

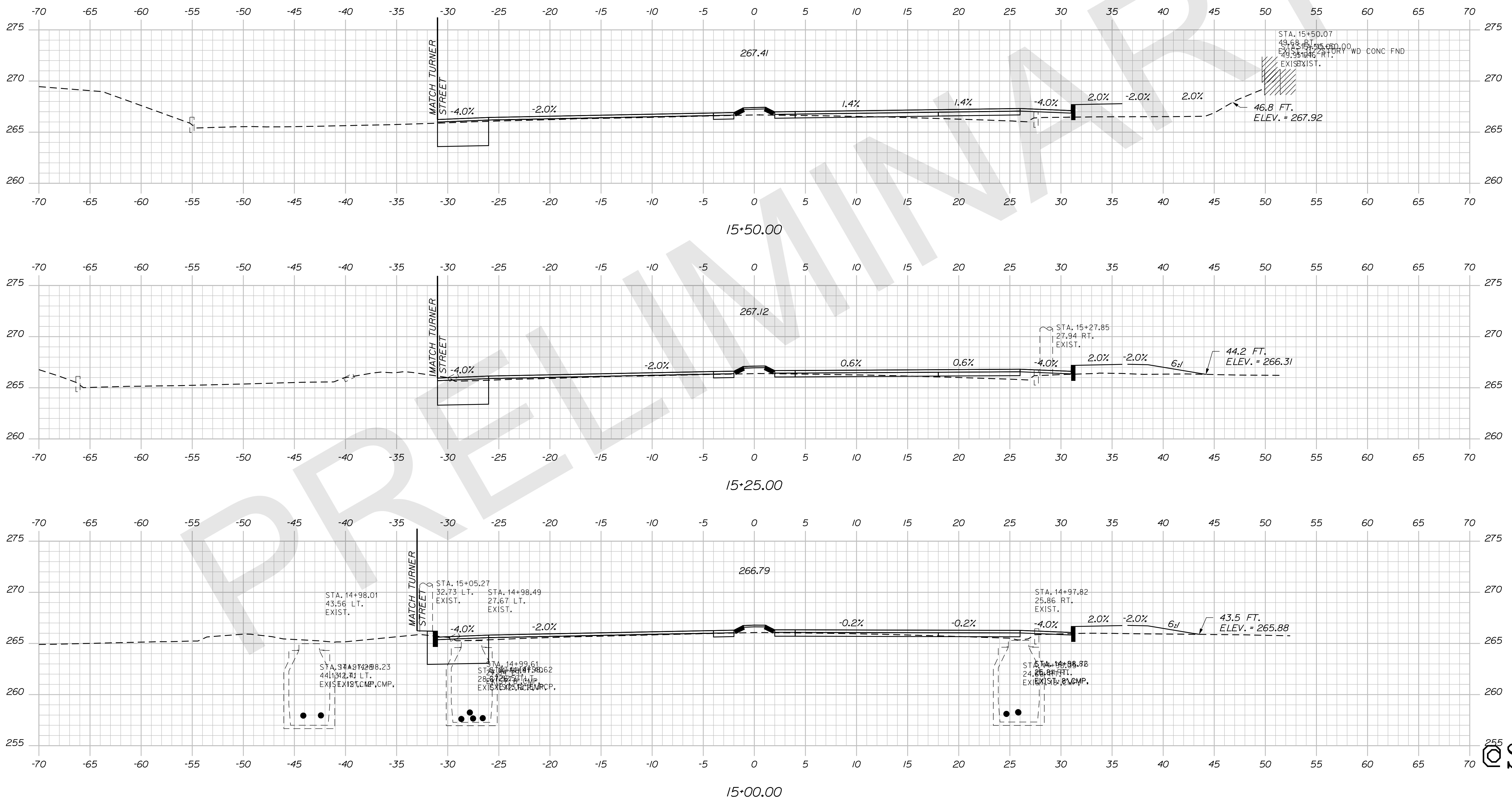

STATE OF MAINE
DEPARTMENT OF TRANSPORTATION

SIGNATURE
P.E. NUMBER
DATE

PROJ. MANAGER	DESIGN-DETAILED	CHECKED-REVIEWED	BY	DATE
\$ProjectMgr\$	\$Designer\$	\$Reviewer\$	\$ProjectMgr\$	\$Date\$
DESIGNS DETAILD 1	DESIGNS DETAILD 2	DESIGNS DETAILD 3	DESIGNS DETAILD 4	DESIGNS DETAILD 5
REVISIONS 1	REVISIONS 2	REVISIONS 3	REVISIONS 4	REVISIONS 5
FIELD CHANGES				

AUBURN
ROUTE 4
CROSS SECTIONS

SHEET NUMBER
OF _

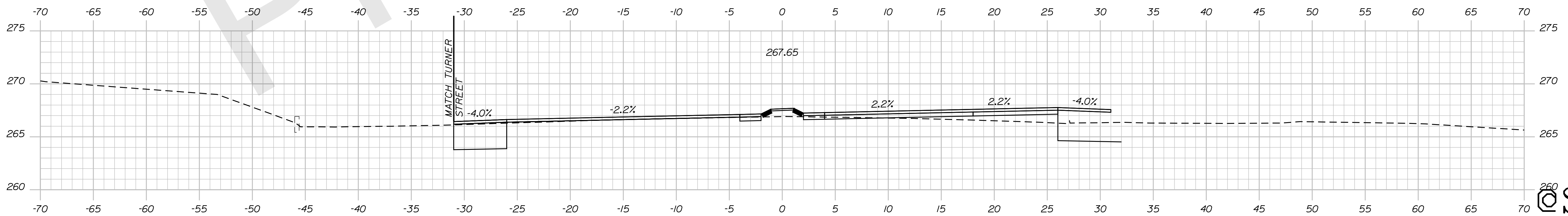
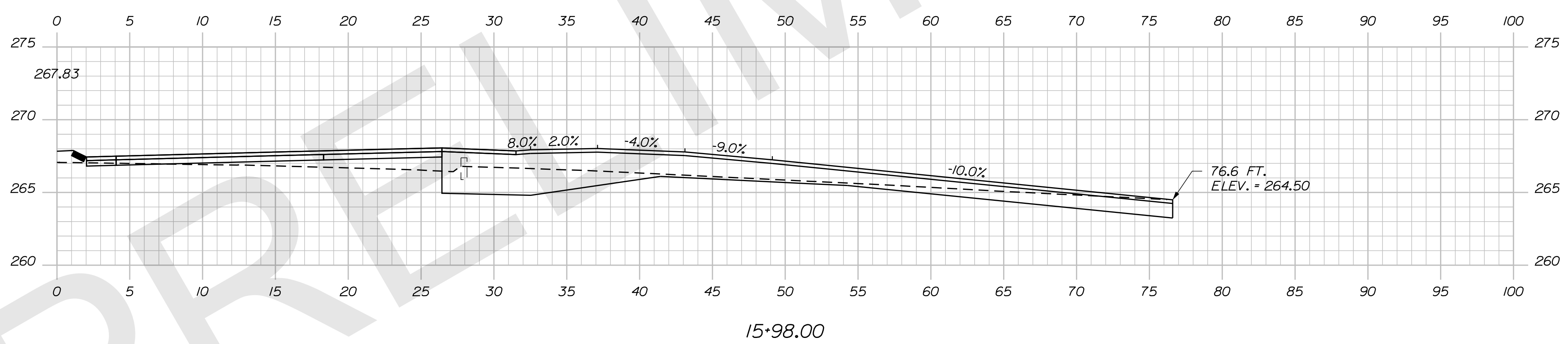
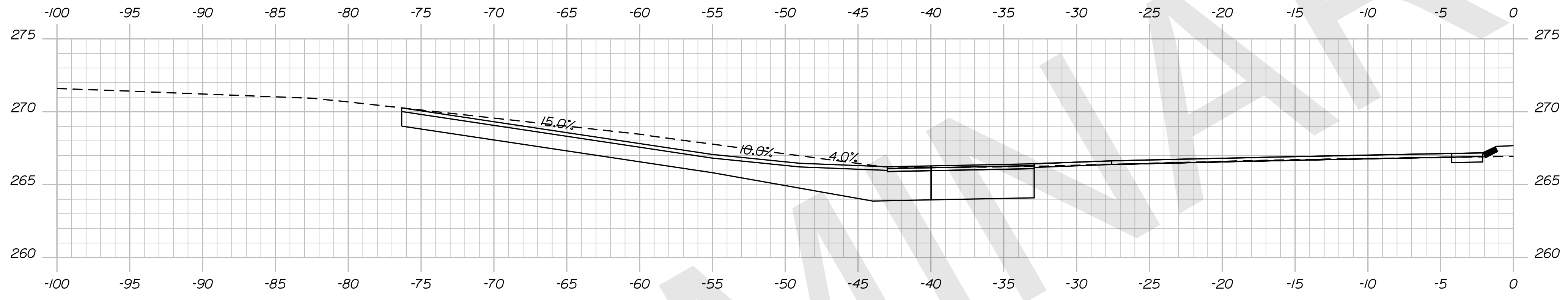
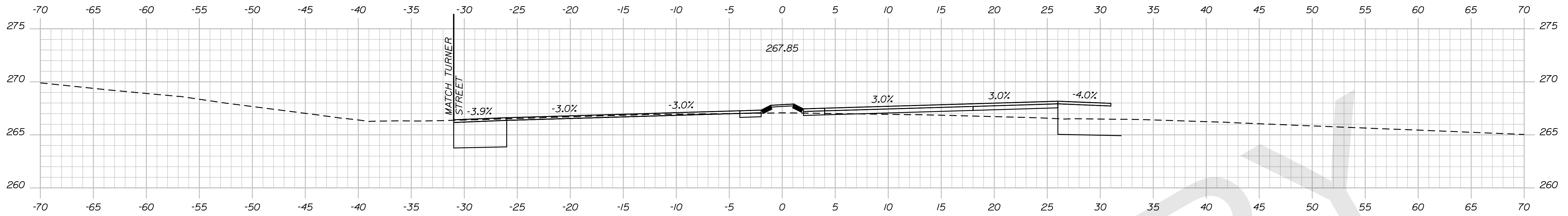

STATE OF MAINE		DEPARTMENT OF TRANSPORTATION	
WIN		WIN WIN 021766.00 HIGHWAY PLANS	
DESIGN-DETAILED	BY	DATE	SIGNATURE
CHECKED-REVIEWED	DESIGNER		
DESIGNS DET AILED	DESIGNER		P.E. NUMBER
DESIGNS DET AILED	DESIGNER		DATE
REVISIONS 1			
REVISIONS 2			
REVISIONS 3			
REVISIONS 4			
FIELD CHANGES			
AUBURN ROUTE 4			
CROSS SECTIONS			
SHEET NUMBER			
OF SHEET			
OF _			

Date: 11/18/2019

Username: clark.e.salloway

Division: HIGHWAY

Filename: ... \MSTAD023_XSECT_16+25_011.dgn

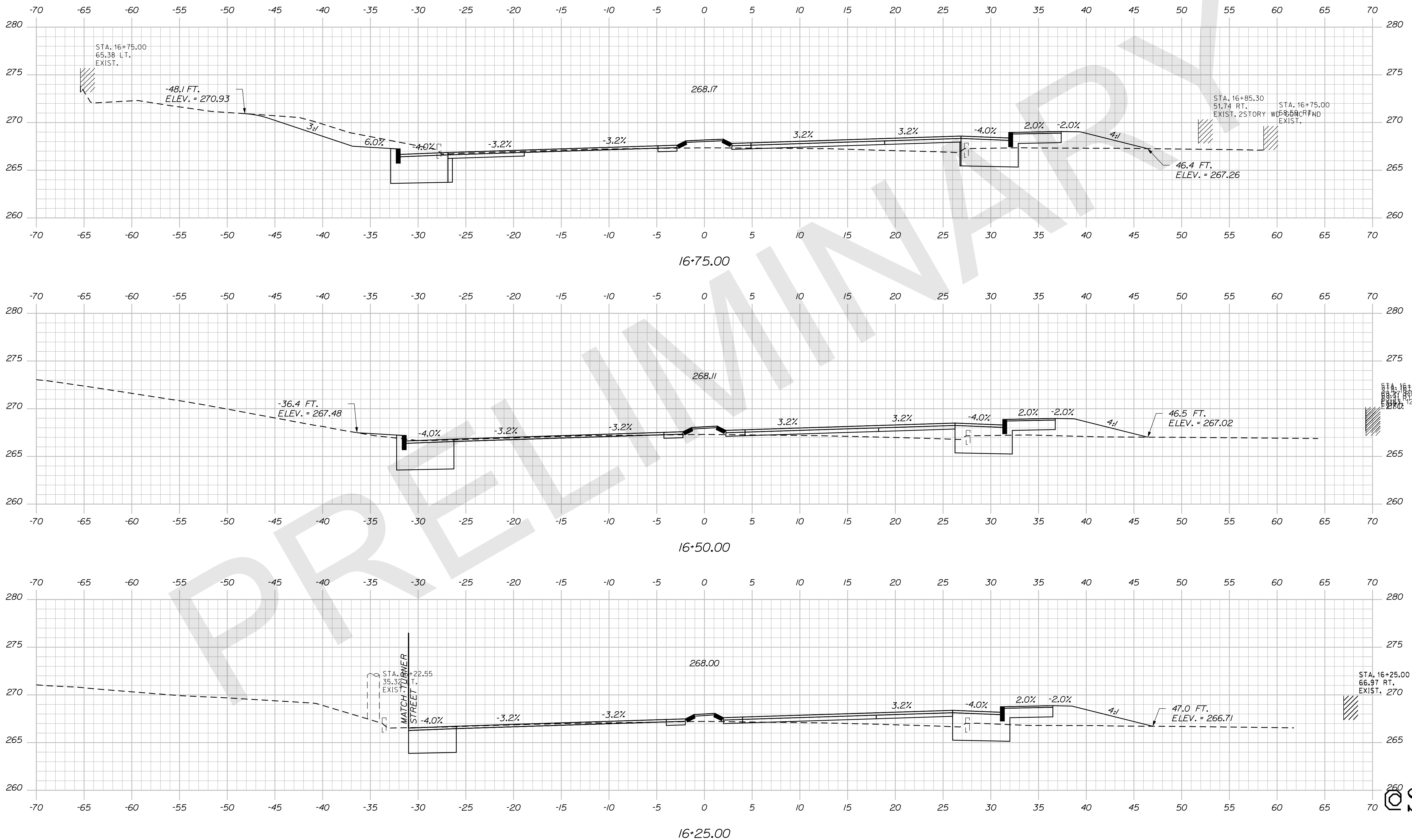

STATE OF MAINE
DEPARTMENT OF TRANSPORTATION

AUBURN
ROUTE 4
CROSS SECTIONS

SHEET NUMBER
260
OF

PROJ. NUMBER	DESIGNER	CHECKED	DESIGNED	REVISIONS	FIELD CHANGES
				1	
				2	
				3	
				4	

BY	DATE	SIGNATURE	P.E. NUMBER	DATE

WIN WIN 021766.00 HIGHWAY PLANS

Date: 11/18/2019

Username: clark.e.sullivan

Division: HIGHWAY

Filename: ... \MSTAD024_XSECT_17-00_012.dgn

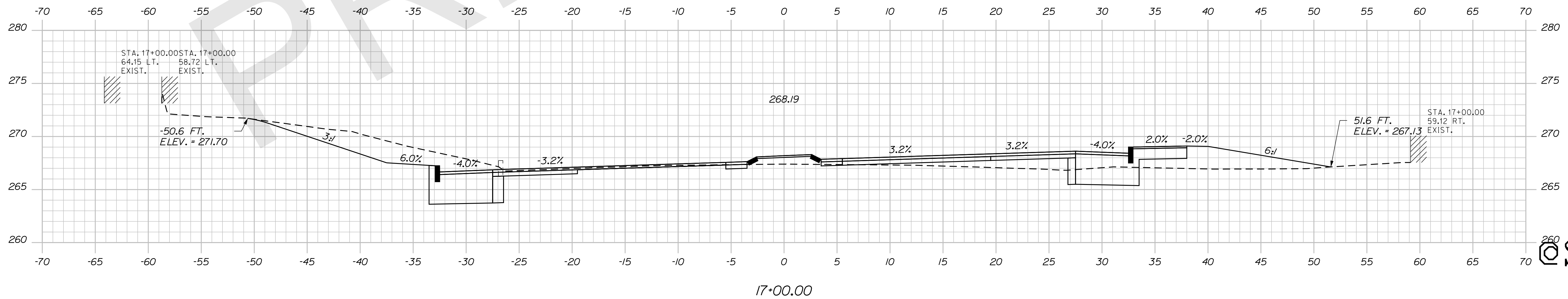
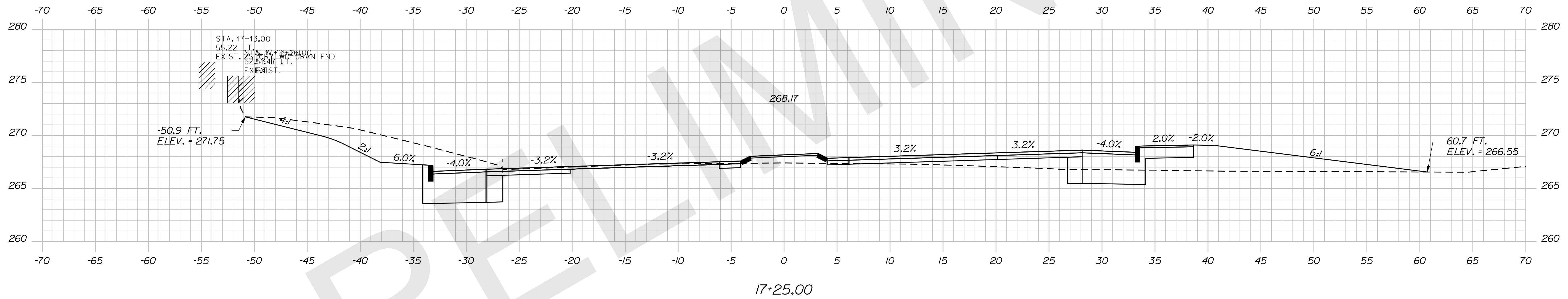
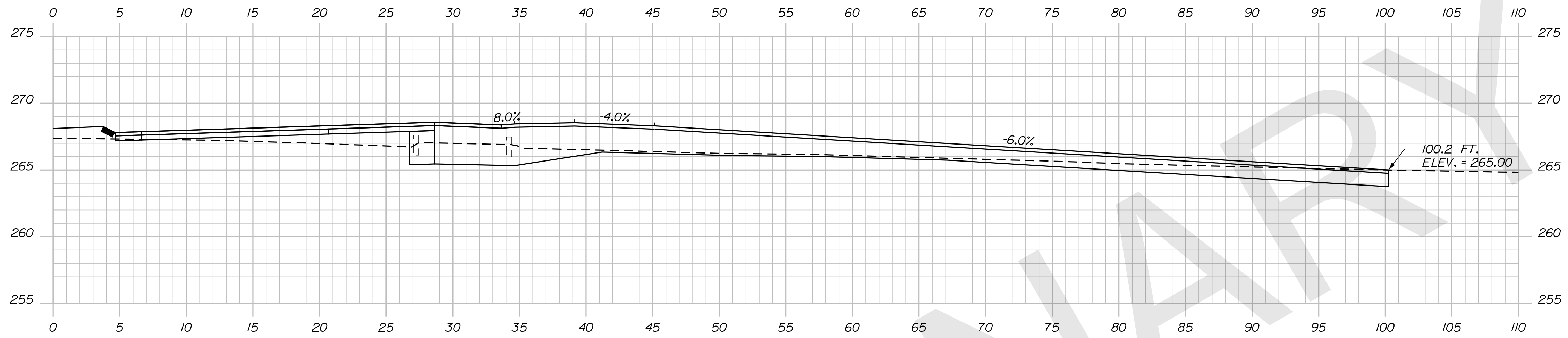

STATE OF MAINE
DEPARTMENT OF TRANSPORTATION

WIN
WIN WIN 021766.00 HIGHWAY PLANS

DESIGNED BY	DATE
CHECKED BY	DATE
DESIGNED BY	DATE
DESIGNED BY	DATE
REVISIONS 1	DATE
REVISIONS 2	DATE
REVISIONS 3	DATE
REVISIONS 4	DATE
FIELD CHANGES	DATE

PROJ. MANAGER	BY	DATE
DESIGNED BY	DESIGNED BY	DATE
CHECKED BY	CHECKED BY	DATE
DESIGNED BY	DESIGNED BY	DATE
DESIGNED BY	DESIGNED BY	DATE
REVISIONS 1	REVISIONS 1	DATE
REVISIONS 2	REVISIONS 2	DATE
REVISIONS 3	REVISIONS 3	DATE
REVISIONS 4	REVISIONS 4	DATE
FIELD CHANGES	FIELD CHANGES	DATE

SIGNATURE
P.E. NUMBER
DATE

AUBURN
ROUTE 4
CROSS SECTIONS

SHEET NUMBER

260
SHEET

OF _

Date: 11/18/2019

Username: clark.e.salloway

Division: HIGHWAY

Filename: ... \MSTAD025_XSECT_17+50_013.dgn

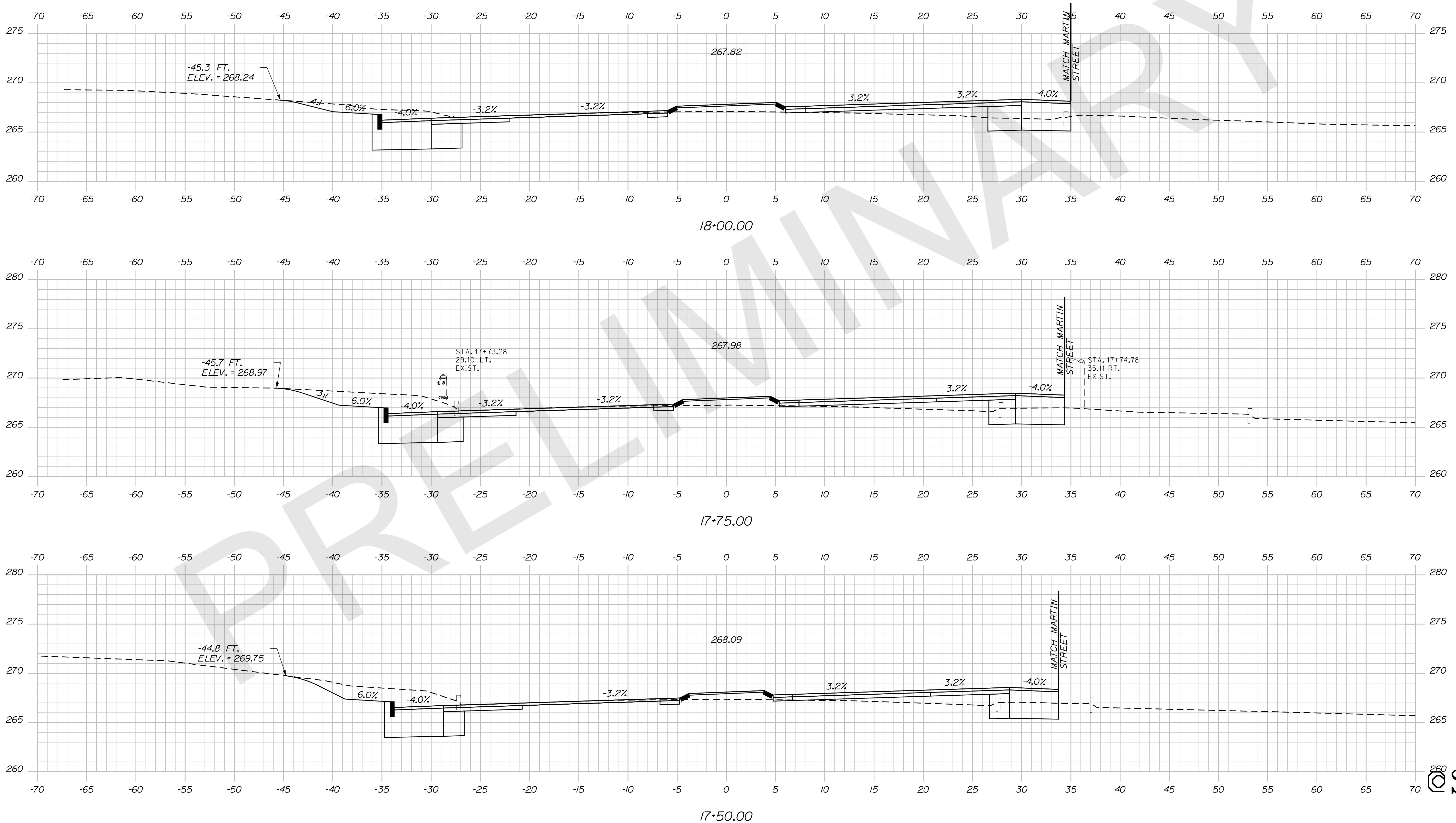

STATE OF MAINE
DEPARTMENT OF TRANSPORTATION

SIGNATURE
P.E. NUMBER
DATE

PROJ. MANAGER	BY	DATE
DESIGN DETAILER	DESIGNER	DATE
CHECKED-REVIEWED	DESIGNER	DATE
DESIGN DETAILER	DESIGNER	DATE
REVISIONS 1		
REVISIONS 2		
REVISIONS 3		
REVISIONS 4		
FIELD CHANGES		

AUBURN
ROUTE 4
CROSS SECTIONS

SHEET NUMBER
260
OF 260

Sta. 17+50.00 to Sta. 18+00.00

Filename: ... \MSTAD026_XSECT_18+25_014.dgn

Division: HIGHWAY

Username: clark.e.sullivan

Date: 11/18/2019

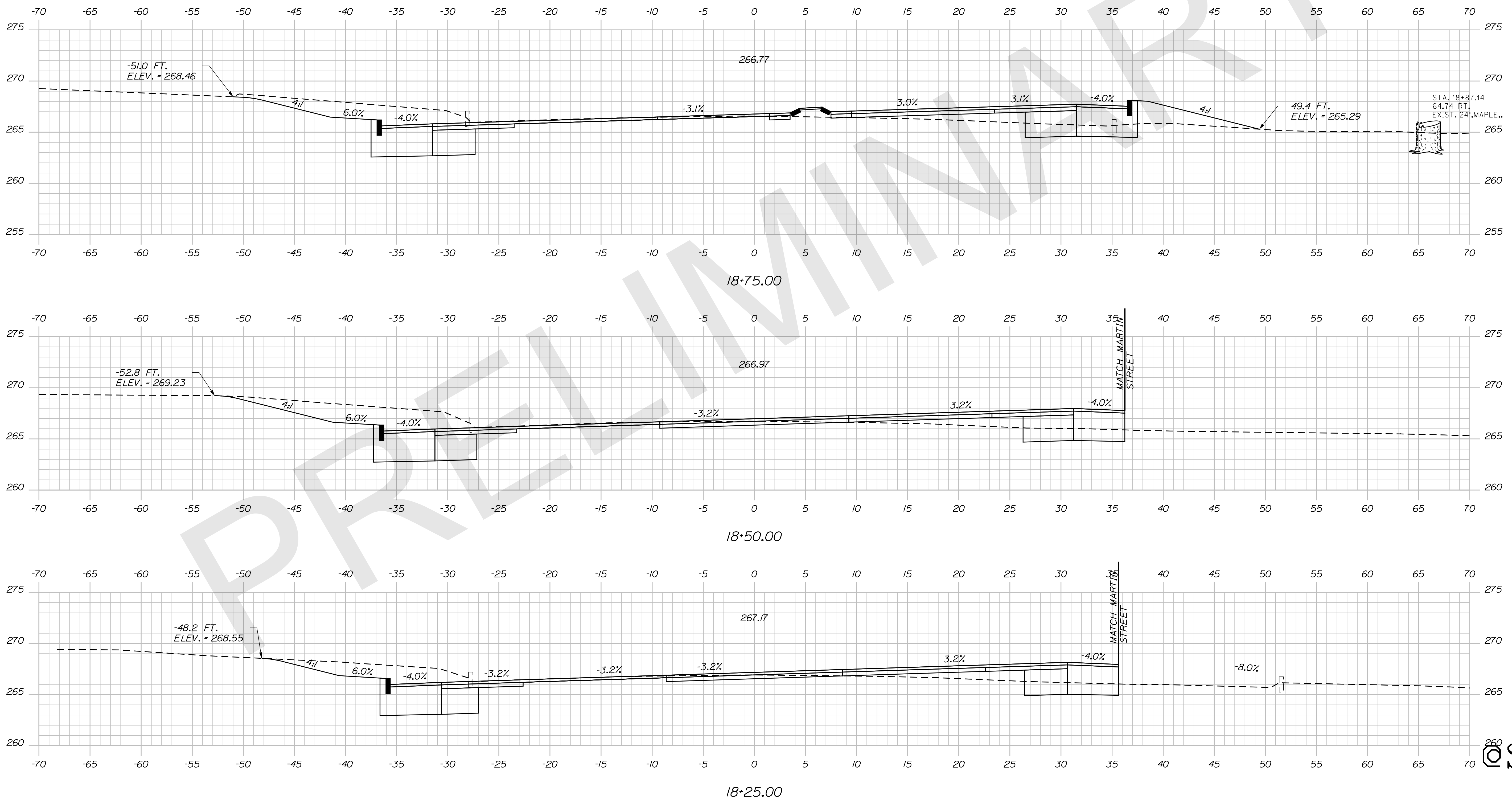

STATE OF MAINE
DEPARTMENT OF TRANSPORTATION

SIGNATURE
P.E. NUMBER
DATE

PROJ. MANAGER	DESIGN-DETAILED	CHECKED-REVIEWED	DESIGN-DETAILED	DESIGN-DETAILED	REVISIONS 1	REVISIONS 2	REVISIONS 3	REVISIONS 4	FIELD CHANGES

AUBURN
ROUTE 4
CROSS SECTIONS

SHEET NUMBER
260
OF **2**

WIN
WIN WIN 021766.00 HIGHWAY PLANS

Date: 11/18/2019

Username: clark.e.salloway

Division: HIGHWAY

Filename: ... \MSTAD027_XSECT_19-00_015.dgn

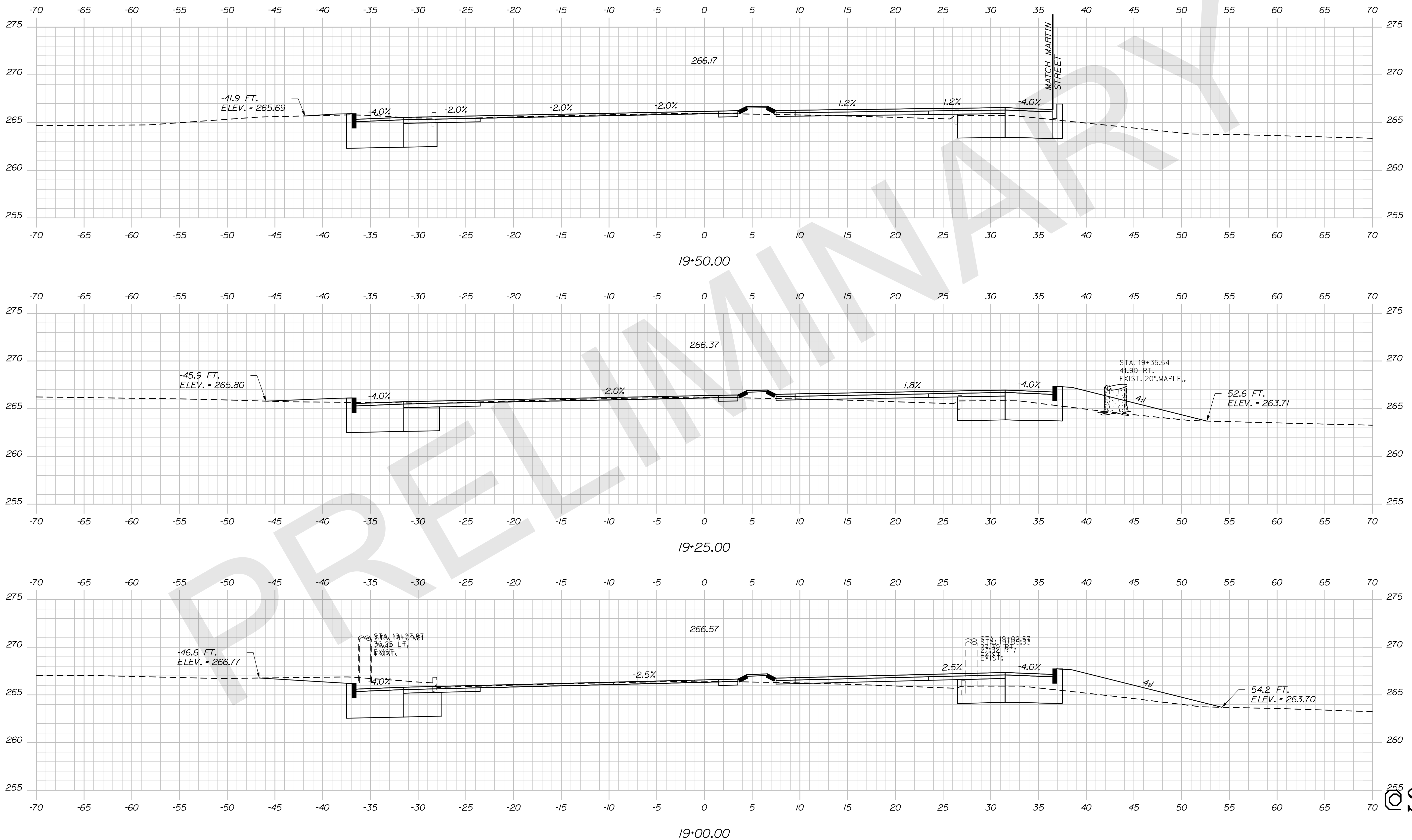

STATE OF MAINE
DEPARTMENT OF TRANSPORTATION

SIGNATURE
P.E. NUMBER
DATE

PROJ. MANAGER	BY	DATE
DESIGN-DETAILED	DESIGNER	DATE
CHECKED-REVIEWED	CHECKER	DATE
DESIGN-DETAILED	DESIGNER	DATE
DESIGN-DETAILED	DESIGNER	DATE
REVISIONS 1		
REVISIONS 2		
REVISIONS 3		
REVISIONS 4		
FIELD CHANGES		

AUBURN
ROUTE 4
CROSS SECTIONS

SHEET NUMBER
OF

Date: 11/18/2019

Username: clark.e.sullivan

Division: HIGHWAY

Filename: ... \MSTAD028_XSECT_19-75_016.dgn

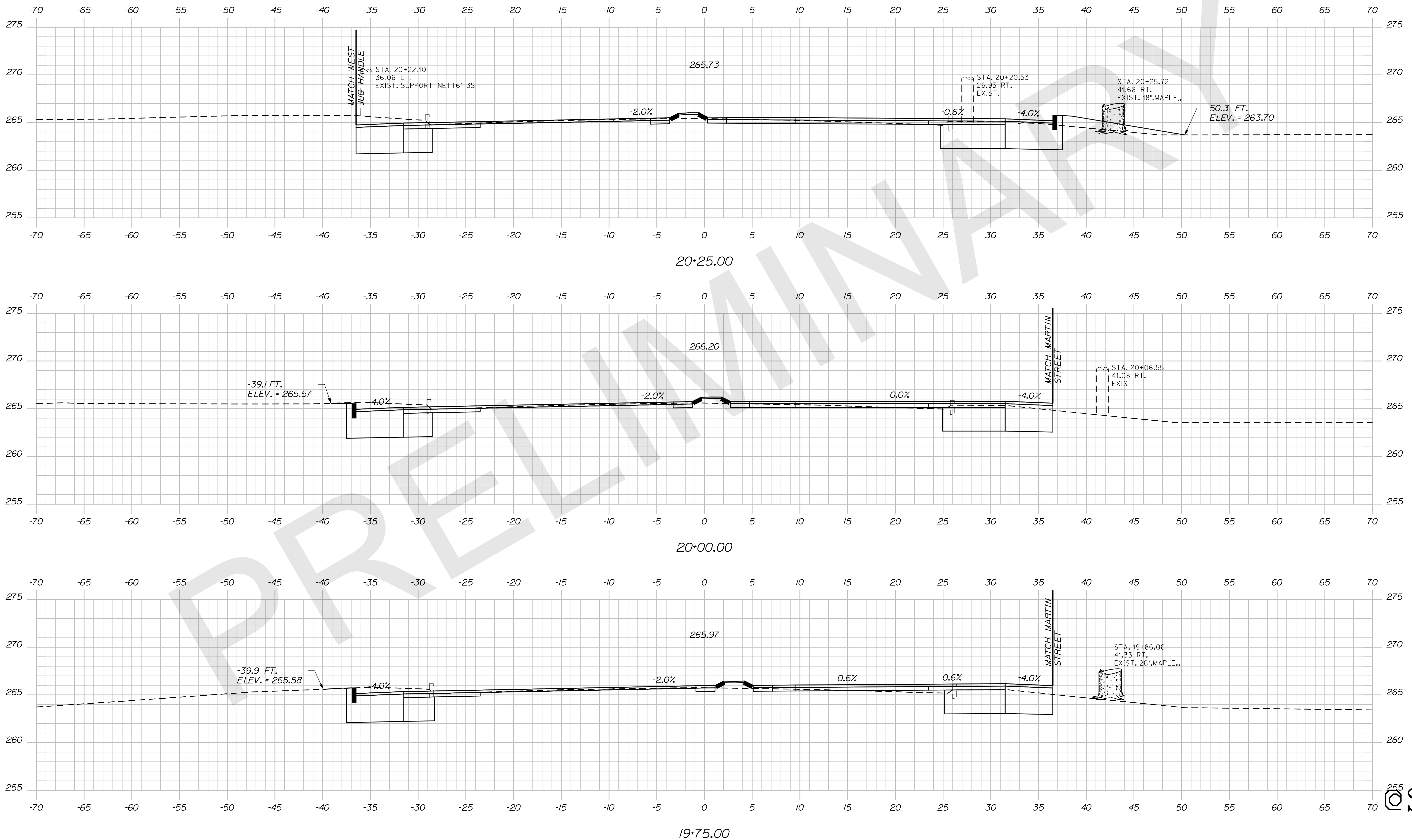

STATE OF MAINE DEPARTMENT OF TRANSPORTATION		WIN WIN WIN 021766.00 HIGHWAY PLANS	
AUBURN ROUTE 4		CROSS SECTIONS	
SHEET NUMBER		255 OF 255	
PROJ. MANAGER	BY	DATE	SIGNATURE
DESIGN DETAILER	DESIGNER	PROJ. DATE	P.E. NUMBER
CHECKED-REVIEWED	DESIGNER 2	PROJ. DATE 2	DATE
DESIGN DETAILER 2	DESIGNER 3	PROJ. DATE 3	
DESIGN DETAILER 3	DESIGNER 4	PROJ. DATE 4	
REVISIONS 1			
REVISIONS 2			
REVISIONS 3			
REVISIONS 4			
FIELD CHANGES			

Sta. 19+75.00 to Sta. 20+25.00

Date: 11/18/2019

Username: clark.e.sullivan

Division: HIGHWAY

Filename: ... \MSTAD029_XSECT_20+50_017.dgn

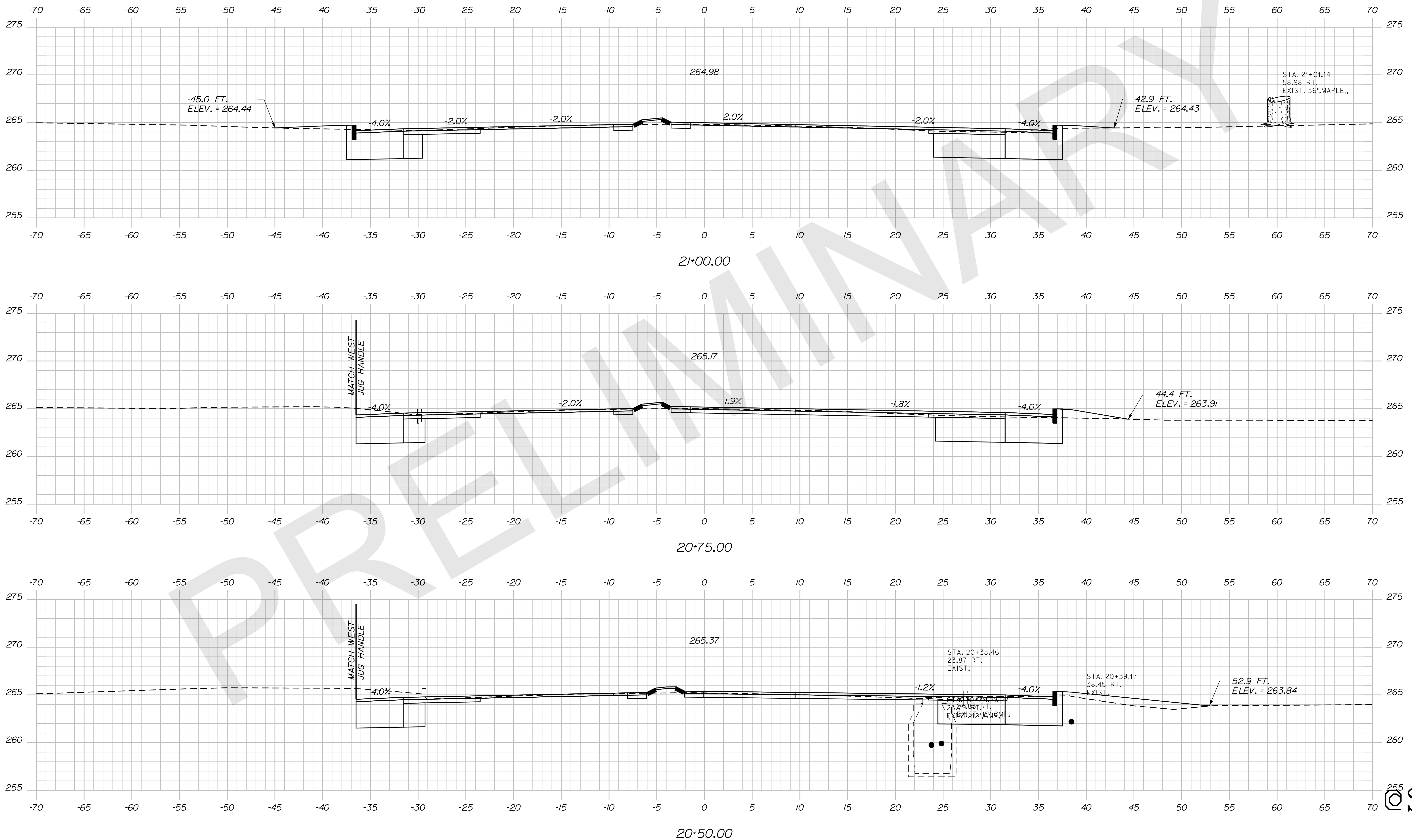

STATE OF MAINE
DEPARTMENT OF TRANSPORTATION

SIGNATURE
P.E. NUMBER
DATE

PROJ. MANAGER	DESIGN DETAILER	CHECKED/REVIEWED	DESIGN DETAILER	REVISIONS 1	REVISIONS 2	REVISIONS 3	REVISIONS 4	FIELD CHANGES

AUBURN
ROUTE 4
CROSS SECTIONS

SHEET NUMBER
OF SHEET

WIN
WIN WIN 021766.00
HIGHWAY PLANS

Date: 11/18/2019

Username: clark.e.sullivan

Division: HIGHWAY

Filename: ... \MSTA030_XSECT_21+25_01B.dgn

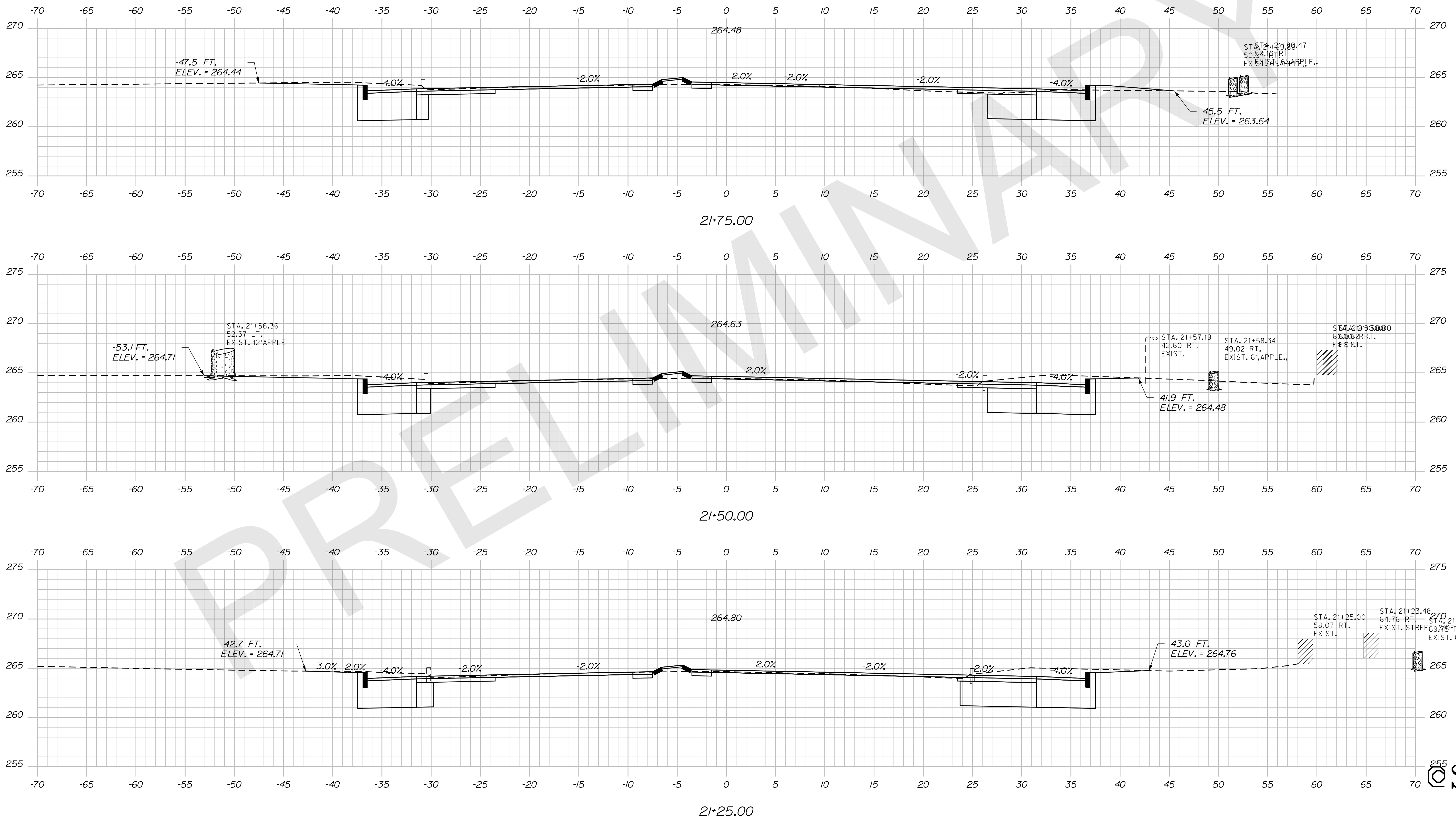

STATE OF MAINE
DEPARTMENT OF TRANSPORTATION

SIGNATURE
P.E. NUMBER
DATE

PROJ. MANAGER	BY	DATE
DESIGN DETAIL	DESIGNER	DATE
CHECKED-REVIEWED	CHECKER	DATE
DESIGN DETAIL	DESIGNER	DATE
DESIGN DETAIL	DESIGNER	DATE
REVISIONS 1		
REVISIONS 2		
REVISIONS 3		
REVISIONS 4		
FIELD CHANGES		

AUBURN
ROUTE 4
CROSS SECTIONS

SHEET NUMBER
OF _

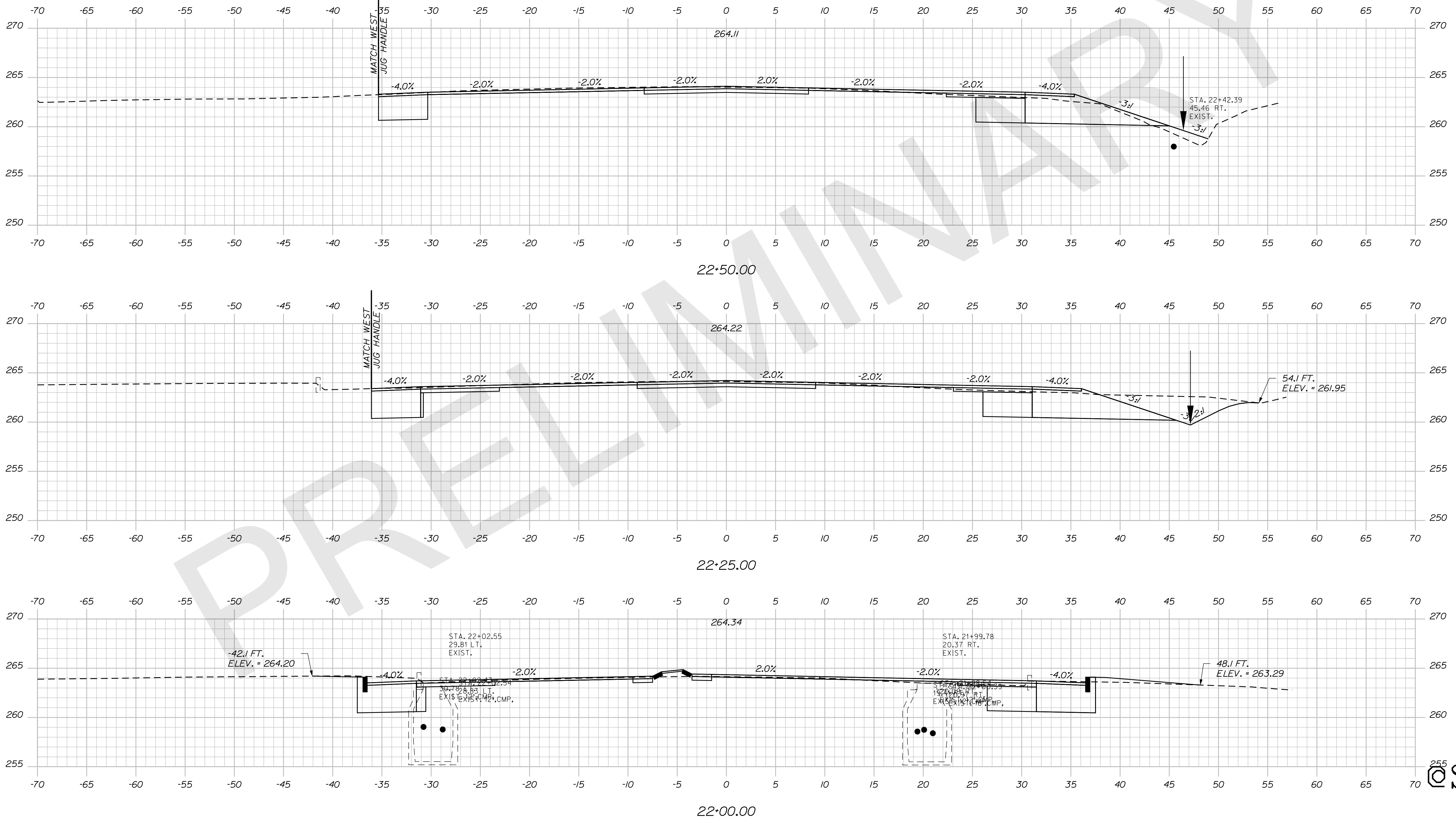

PROJ. MANAGER	BY	DATE	SIGNATURE
DESIGN-DETAILED	DESIGNER	DATE	
CHECKED-REVIEWED	CHECKER	DATE	
DESIGN-DETAILED	DESIGNER	DATE	
DESIGN-DETAILED	DESIGNER	DATE	
REVISIONS 1	REVISION	DATE	
REVISIONS 2	REVISION	DATE	
REVISIONS 3	REVISION	DATE	
REVISIONS 4	REVISION	DATE	
FIELD CHANGES	FIELD	DATE	

AUBURN
ROUTE 4
CROSS SECTIONS

Date: 11/18/2019

Username: clark.e.sullivan

Division: HIGHWAY

Filename: ... \MSTAD032_XSECT_22-75_020.dgn

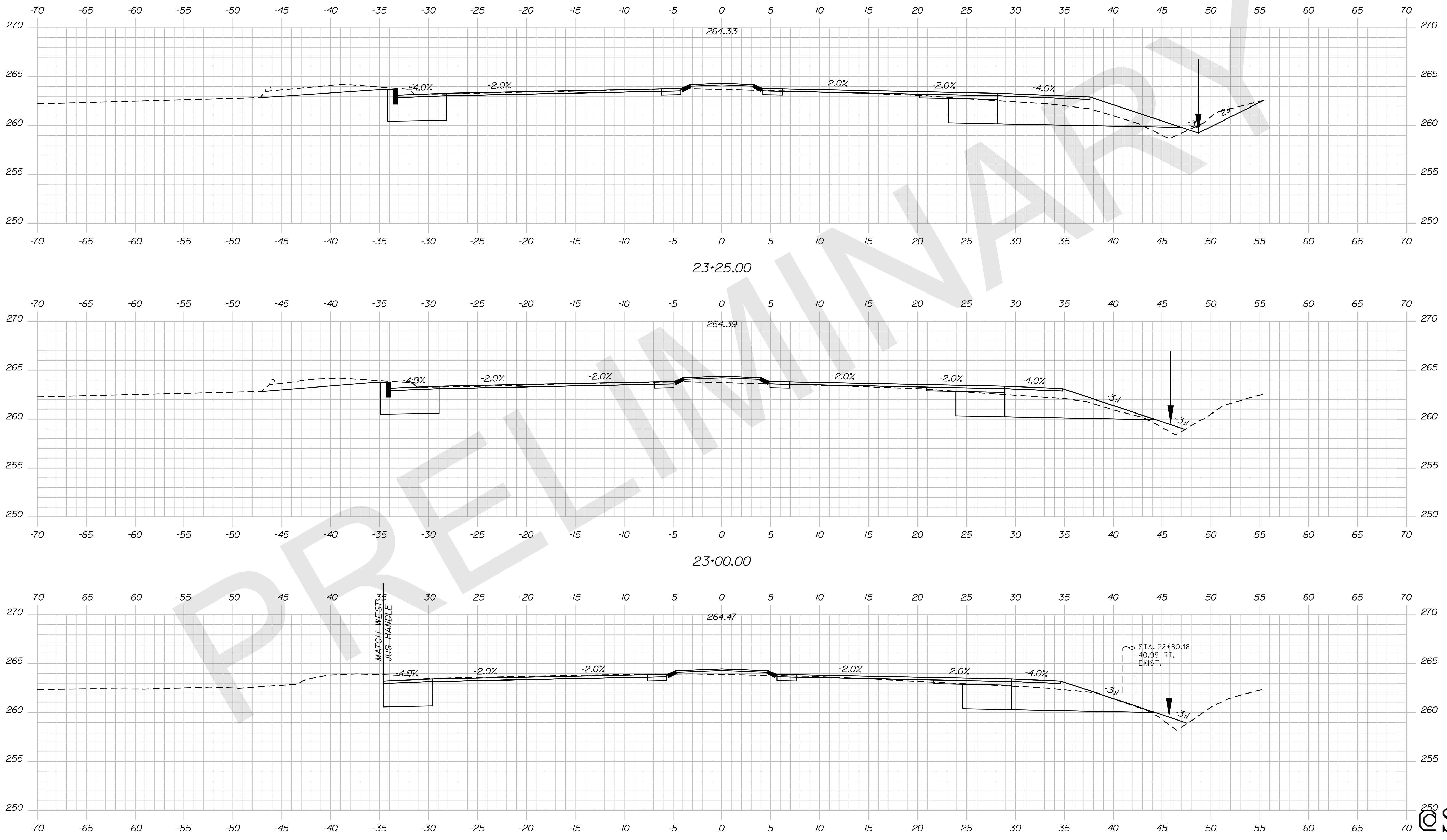

STATE OF MAINE
DEPARTMENT OF TRANSPORTATION

PROJ. MANAGER	DESIGN-DETAILED	CHECKED-REVIEWED	DESIGN-DETAILED	DESIGN-DETAILED	REVISIONS 1	REVISIONS 2	REVISIONS 3	REVISIONS 4	FIELD CHANGES
BY	DATE	BY	DATE	BY	DATE	BY	DATE	BY	DATE
DESIGNER	DATE	DESIGNER	DATE	DESIGNER	DATE	DESIGNER	DATE	DESIGNER	DATE
PROJ. NO.	PROJ. NO.	PROJ. NO.	PROJ. NO.	PROJ. NO.	PROJ. NO.	PROJ. NO.	PROJ. NO.	PROJ. NO.	PROJ. NO.
SIGNATURE	SIGNATURE	SIGNATURE	SIGNATURE	SIGNATURE	SIGNATURE	SIGNATURE	SIGNATURE	SIGNATURE	SIGNATURE
P.E. NUMBER	P.E. NUMBER	P.E. NUMBER	P.E. NUMBER	P.E. NUMBER	P.E. NUMBER	P.E. NUMBER	P.E. NUMBER	P.E. NUMBER	P.E. NUMBER
DATE	DATE	DATE	DATE	DATE	DATE	DATE	DATE	DATE	DATE

AUBURN
ROUTE 4
CROSS SECTIONS

SHEET NUMBER
250
OF SHEET
OF _

Date: 11/18/2019

Username: clark.e.sullivan

Division: HIGHWAY

Filename: ... \MSTAD033_XSECT_23+50_021.dgn

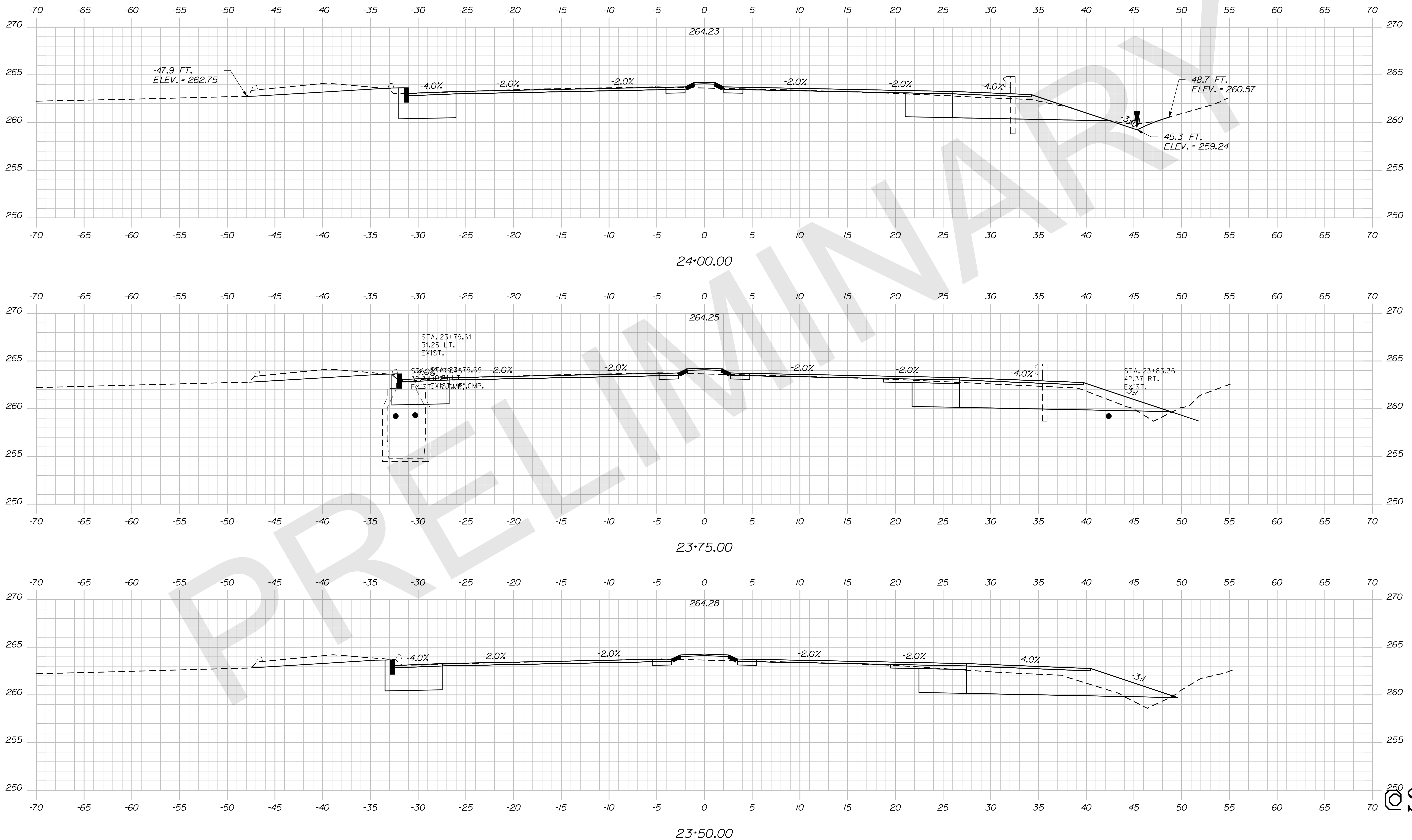

STATE OF MAINE
DEPARTMENT OF TRANSPORTATION

SIGNATURE
P.E. NUMBER
DATE

PROJ. MANAGER	BY	DATE
DESIGN-DETAILED	DESIGNER	DATE
CHECKED-REVIEWED	CHECKER	DATE
DESIGN-DETAILED	DESIGNER	DATE
DESIGN-DETAILED	DESIGNER	DATE
REVISIONS 1	DATE	
REVISIONS 2	DATE	
REVISIONS 3	DATE	
REVISIONS 4	DATE	
FIELD CHANGES	DATE	

AUBURN
ROUTE 4
CROSS SECTIONS

SHEET NUMBER
OF

Date: 11/18/2019

Username: clark.e.sullivan

Division: HIGHWAY

Filename: ... \MSTAD034_XSECT_24+25_022.dgn

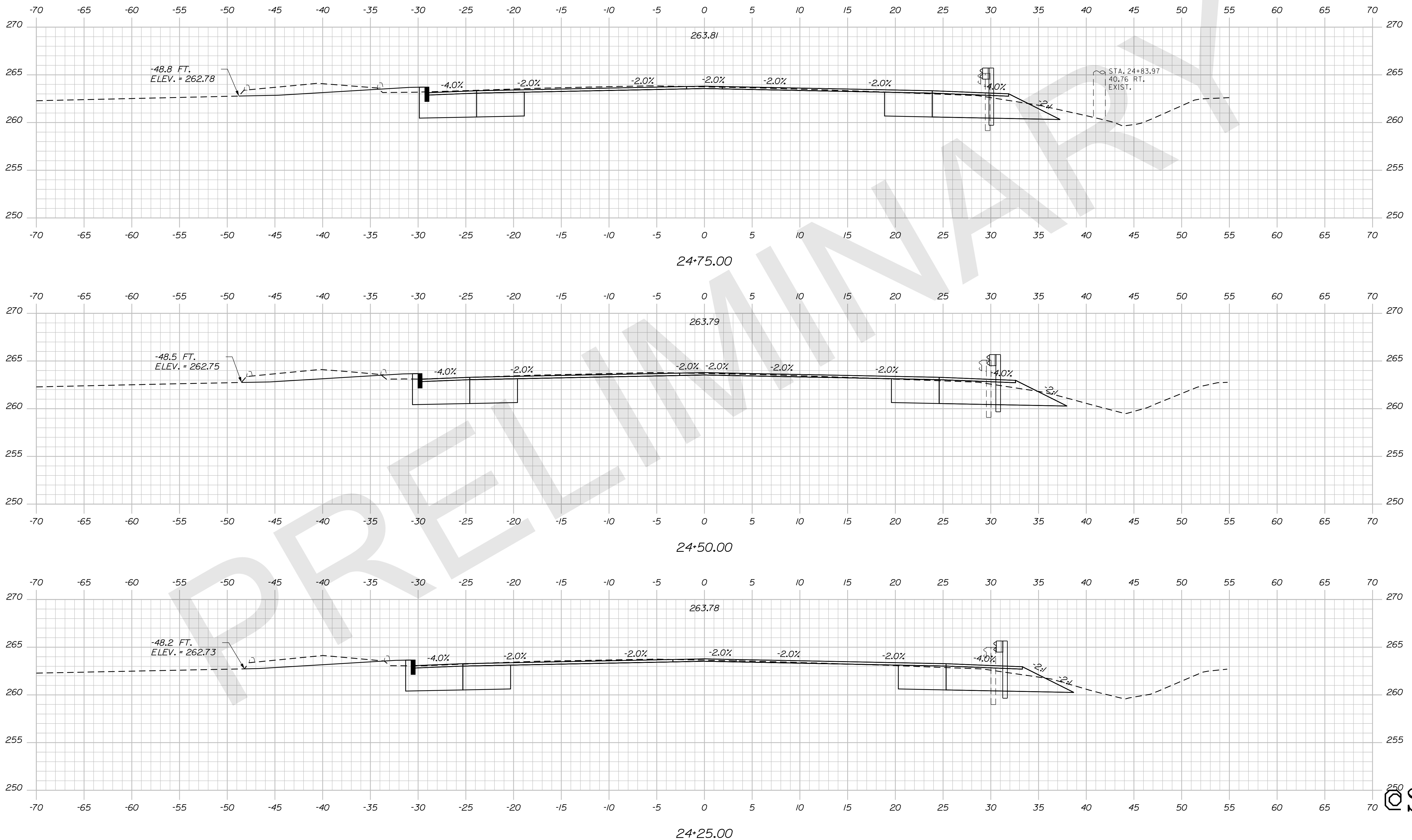

STATE OF MAINE
DEPARTMENT OF TRANSPORTATION

SIGNATURE
P.E. NUMBER
DATE

PROJ. MANAGER	BY	DATE
DESIGN-DETAILED	DESIGNER	DATE
CHECKED-REVIEWED	CHECKER	DATE
DESIGN-DETAILED	DESIGNER	DATE
DESIGN-DETAILED	DESIGNER	DATE
REVISIONS 1		
REVISIONS 2		
REVISIONS 3		
REVISIONS 4		
FIELD CHANGES		

AUBURN
ROUTE 4
CROSS SECTIONS

SHEET NUMBER
OF

Date: 11/18/2019

Username: clark.e.sullivan

Division: HIGHWAY

Filename: ... \MSTAD035_XSECT_25+00_023.dgn

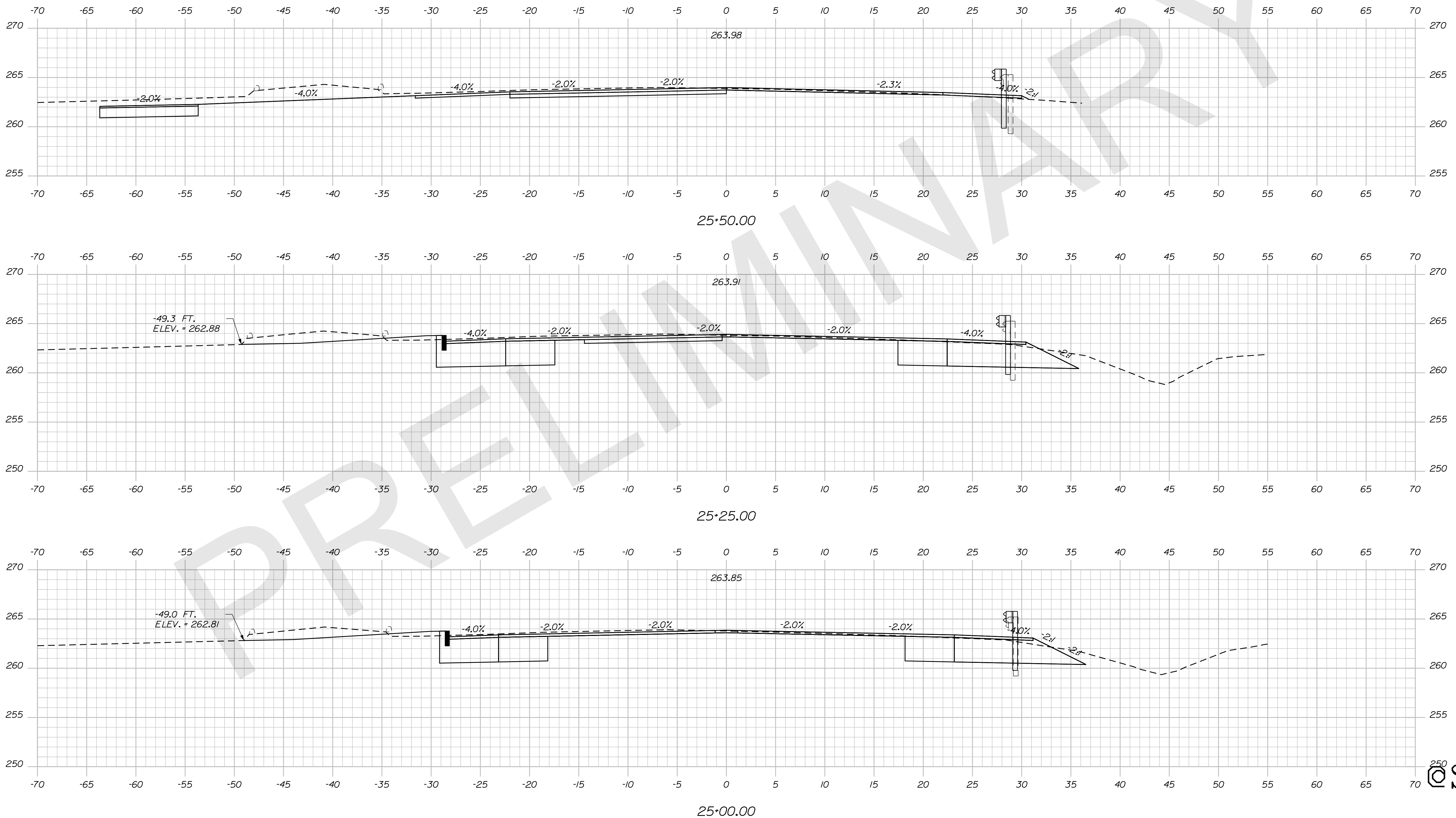

STATE OF MAINE
DEPARTMENT OF TRANSPORTATION

SIGNATURE
P.E. NUMBER
DATE

PROJ. MANAGER	BY	DATE
DESIGN-DETAILED	DESIGNER	DATE
CHECKED-REVIEWED	CHECKER	DATE
DESIGN-DETAILED	DESIGNER	DATE
DESIGN-DETAILED	DESIGNER	DATE
REVISIONS 1	DESIGNER	DATE
REVISIONS 2	DESIGNER	DATE
REVISIONS 3	DESIGNER	DATE
REVISIONS 4	DESIGNER	DATE
FIELD CHANGES	DESIGNER	DATE

AUBURN
ROUTE 4
CROSS SECTIONS

SHEET NUMBER
OF SHEET

Date: 11/18/2019

Username: clark.e.sullivan

Division: HIGHWAY

Filename: ... \MSTA\037_XSECT_27+50_025.dgn

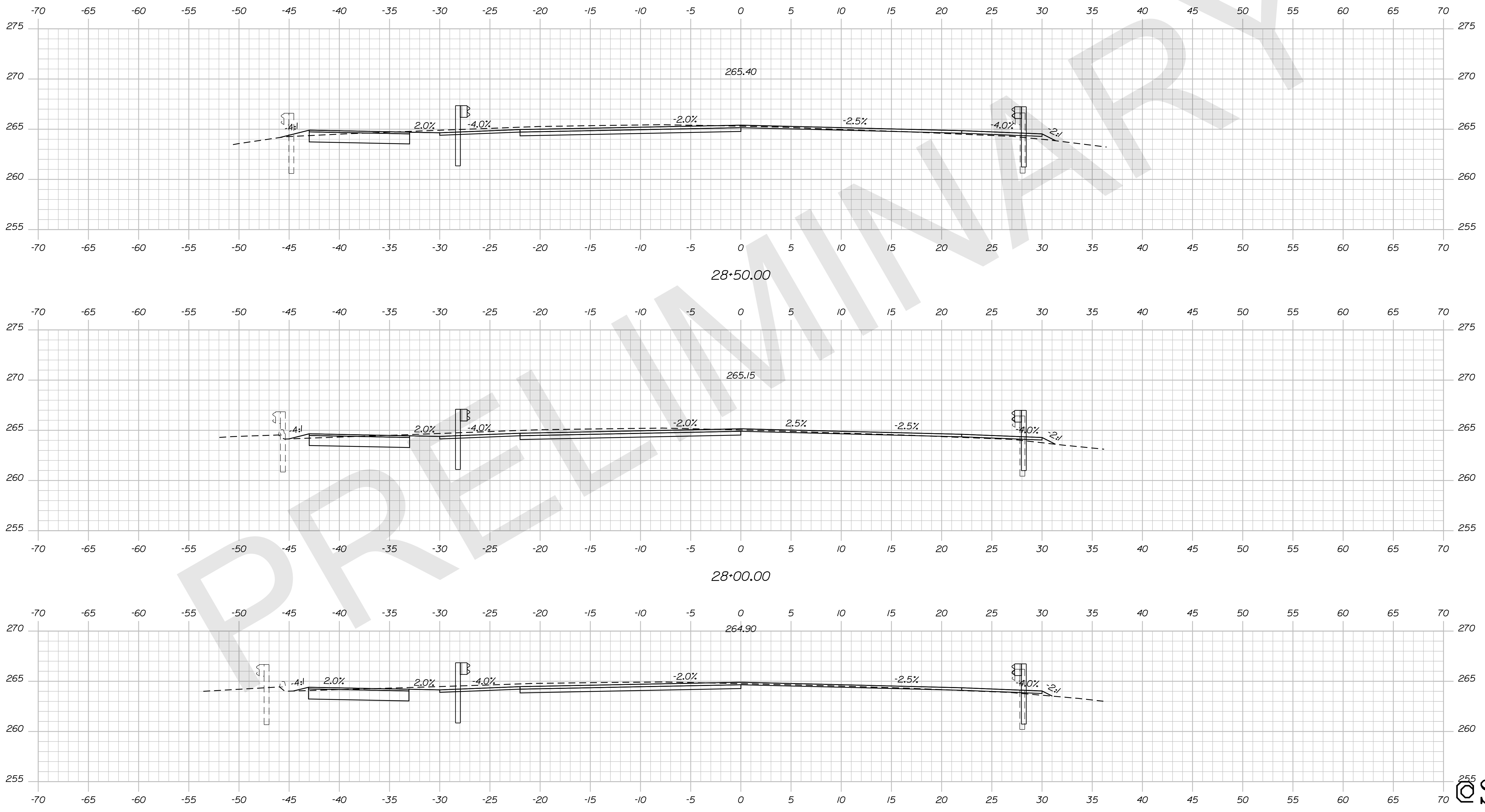

STATE OF MAINE
DEPARTMENT OF TRANSPORTATION

PROJ. MANAGER	BY	DATE
CHECKED-REVIEWED	DESIGNER	DATE
DESIGN DETAIL	DESIGNER	DATE
DESIGN DETAIL	DESIGNER	DATE
REVISIONS 1	REVISION	DATE
REVISIONS 2	REVISION	DATE
REVISIONS 3	REVISION	DATE
REVISIONS 4	REVISION	DATE
FIELD CHANGES	FIELD	DATE

AUBURN
ROUTE 4
CROSS SECTIONS

SHEET NUMBER
OF SHEET

WIN
WIN WIN 021766.00 HIGHWAY PLANS

Date: 11/18/2019

Username: clark.e.sullivan

Division: HIGHWAY

Filename: ... \MSTAD038_XSECT_29-00_026.dgn

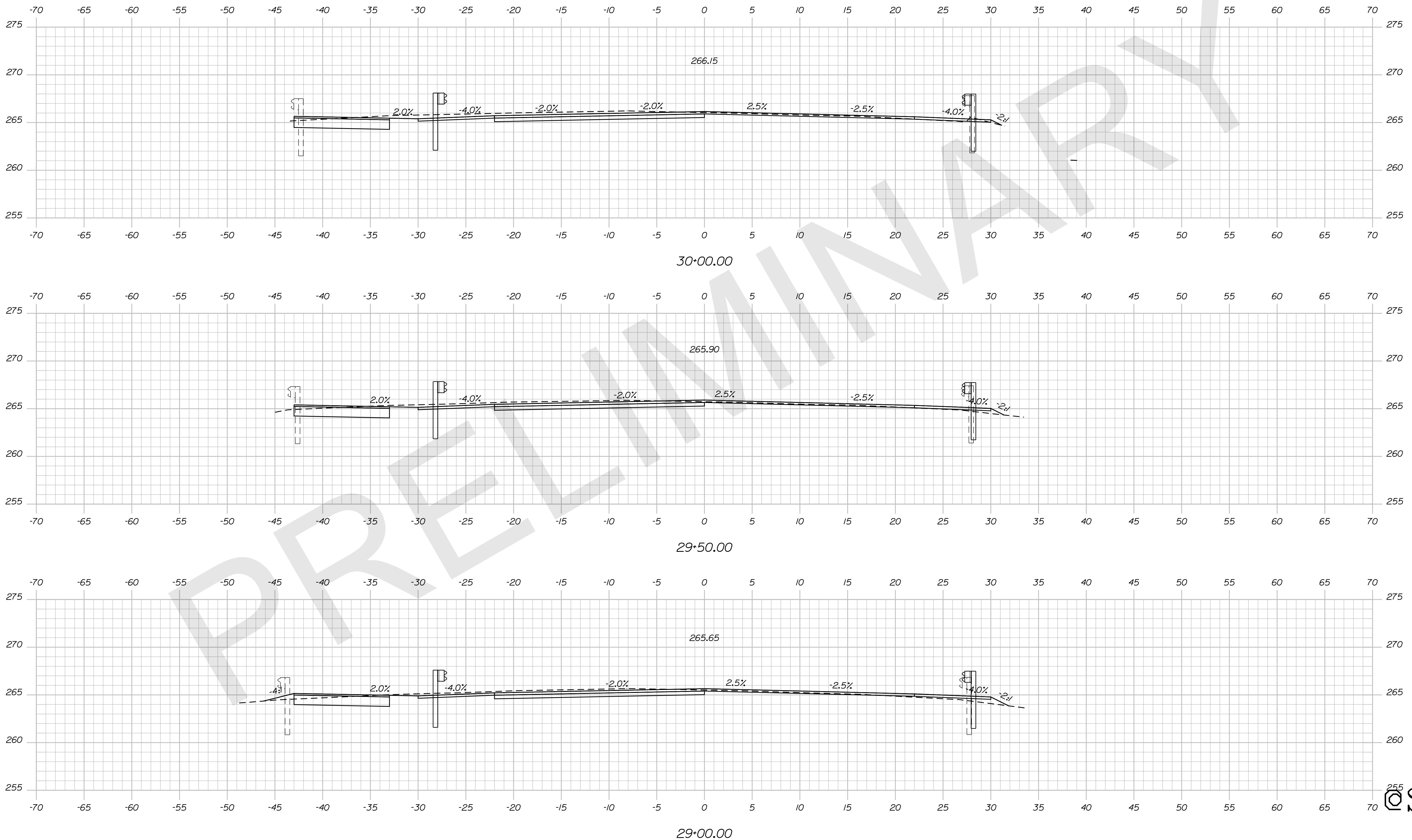

STATE OF MAINE
DEPARTMENT OF TRANSPORTATION

SIGNATURE _____
P.E. NUMBER _____
DATE _____

PROJ. MANAGER	DESIGNER	CHECKED	DATE
PROJMANAGER1	DESIGNER1	CHECKED1	DATE1
PROJMANAGER2	DESIGNER2	CHECKED2	DATE2
PROJMANAGER3	DESIGNER3	CHECKED3	DATE3
PROJMANAGER4	DESIGNER4	CHECKED4	DATE4

AUBURN
ROUTE 4
CROSS SECTIONS

SHEET NUMBER
26
OF 26

WIN
WIN WIN 021766.00
HIGHWAY PLANS

Date: 11/18/2019

Username: clark.e.sullivan

Division: HIGHWAY

Filename: ... \MSTAD039_XSECT_30+50_027.dgn

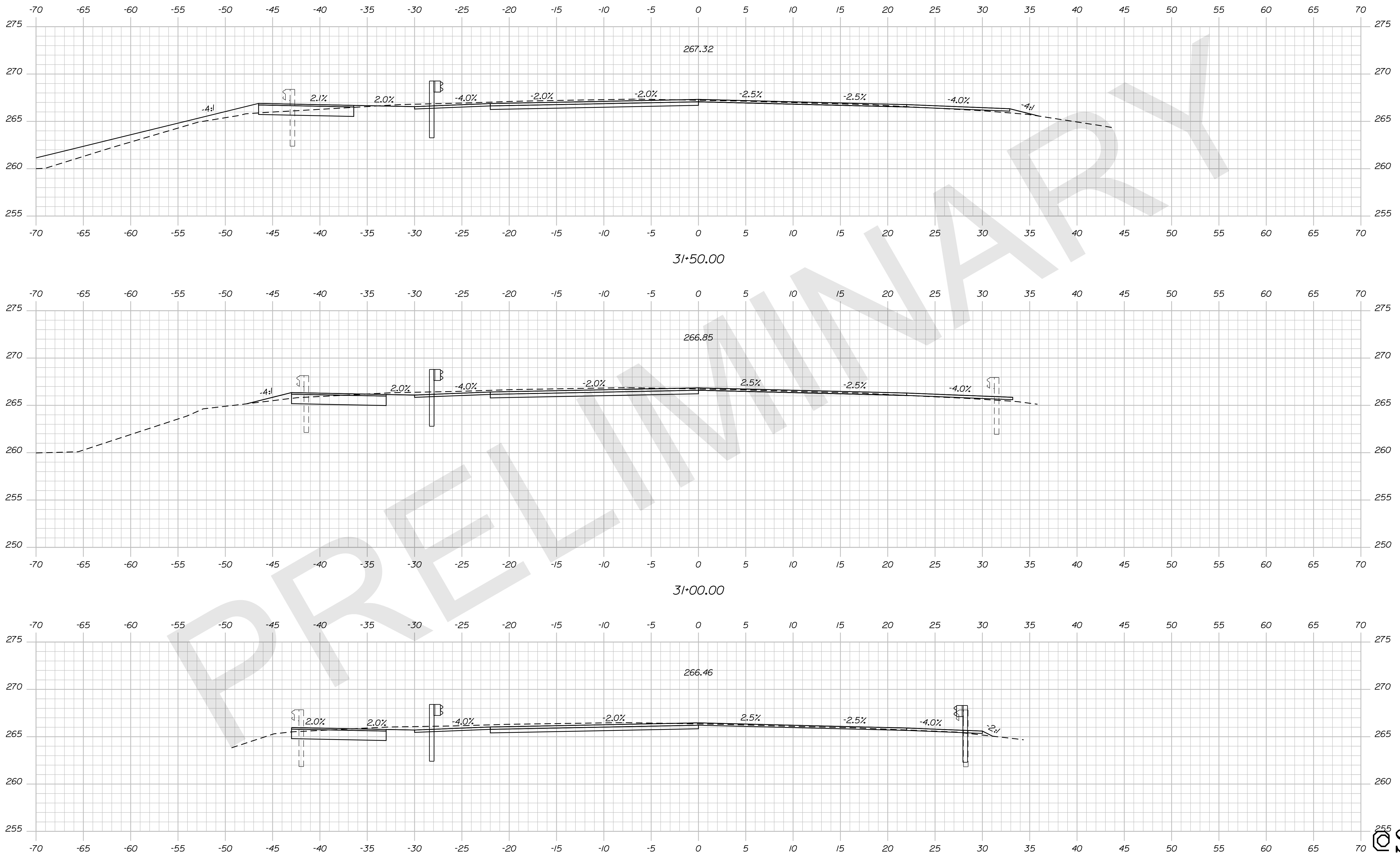

STATE OF MAINE
DEPARTMENT OF TRANSPORTATION

WIN
WIN WIN 021766.00
HIGHWAY PLANS

PROJ. MANAGER	BY	DATE	SIGNATURE
DESIGN-DETAILED	DESIGNER	DATE	
CHECKED-REVIEWED	CHECKER	DATE	
DESIGN-DETAILED	DESIGNER	DATE	
DESIGN-DETAILED	DESIGNER	DATE	
REVISIONS 1			
REVISIONS 2			
REVISIONS 3			
REVISIONS 4			
FIELD CHANGES			

AUBURN
ROUTE 4
CROSS SECTIONS

SHEET NUMBER
OF SHEET

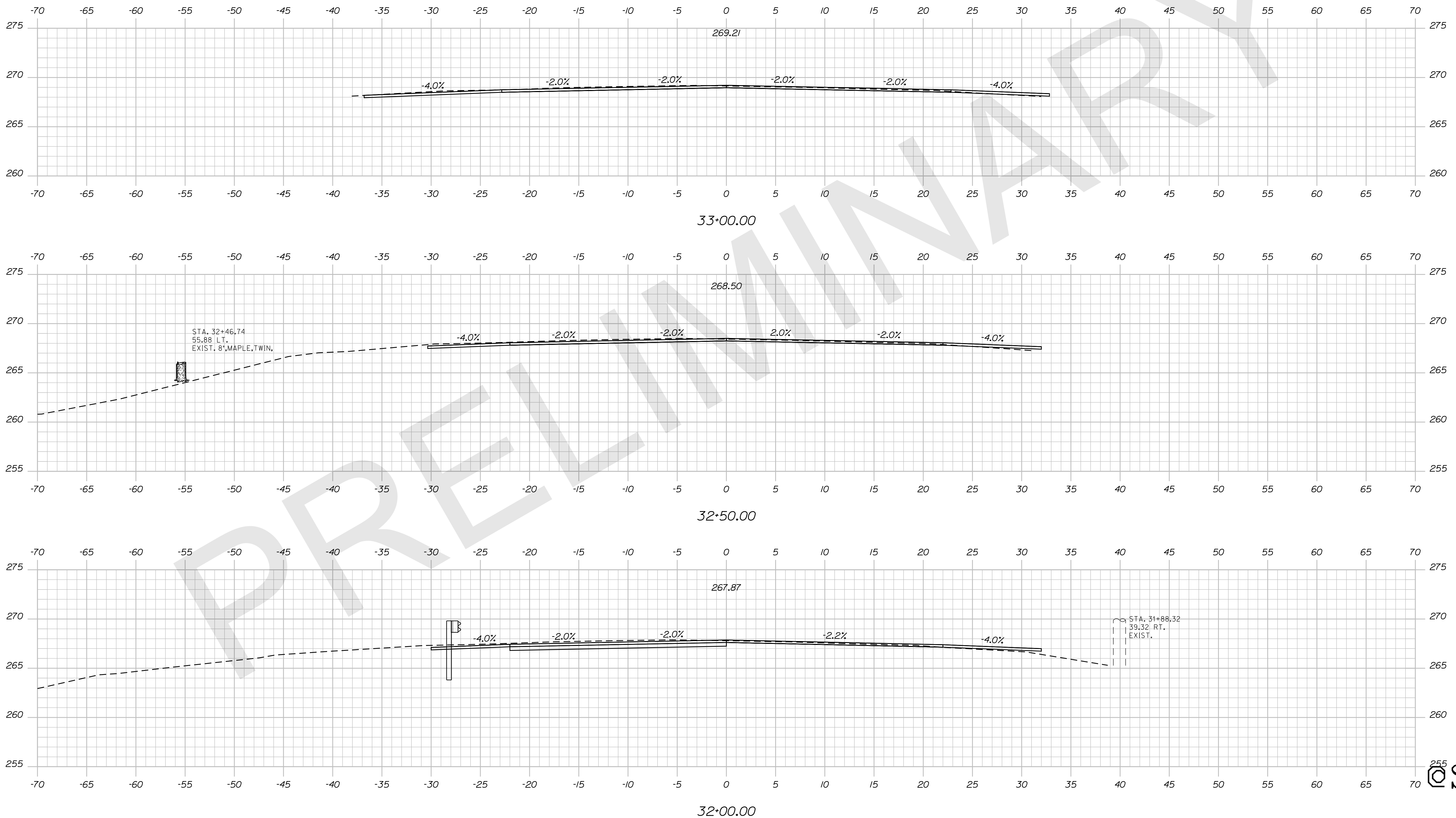

STATE OF MAINE
 DEPARTMENT OF TRANSPORTATION

SIGNATURE
 P.E. NUMBER
 DATE

PROJ. MANAGER	BY	DATE
DESIGN-DETAILED	DESIGNER	DATE
CHECKED-REVIEWED	DESIGNER	DATE
DESIGN-DETAILED	DESIGNER	DATE
DESIGN-DETAILED	DESIGNER	DATE
REVISIONS 1	DESIGNER	DATE
REVISIONS 2	DESIGNER	DATE
REVISIONS 3	DESIGNER	DATE
REVISIONS 4	DESIGNER	DATE
FIELD CHANGES	DESIGNER	DATE

AUBURN
 ROUTE 4
 CROSS SECTIONS

SHEET NUMBER
 OF _



STATE OF MAINE DEPARTMENT OF TRANSPORTATION		SIGNATURE	
WIN WIN WIN 021766.00 HIGHWAY PLANS		P.E. NUMBER	
		DATE	
PROJ. MANAGER	BY	DATE	
DESIGN-DETAILED	DESIGNER	DATE	
CHECKED-REVIEWED	CHECKER	DATE	
DESIGN-DETAILED	DESIGNER	DATE	
DESIGN-DETAILED	DESIGNER	DATE	
REVISIONS 1			
REVISIONS 2			
REVISIONS 3			
REVISIONS 4			
FIELD CHANGES			

AUBURN
ROUTE 4

CROSS SECTIONS

SHEET NUMBER

260 OF SHEET

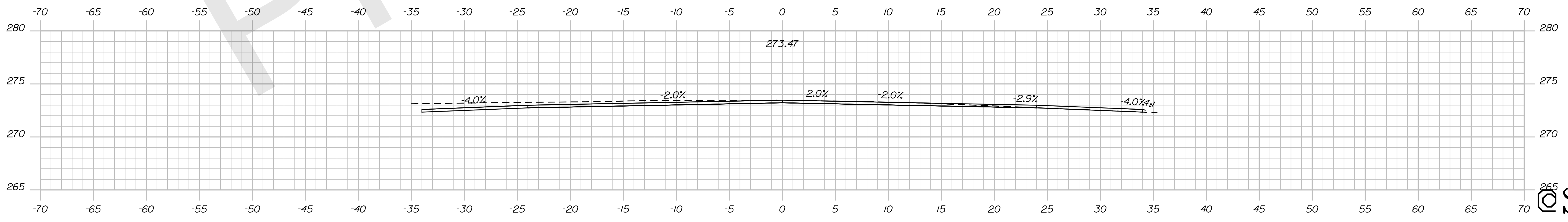

35+35.00

STATE OF MAINE
DEPARTMENT OF TRANSPORTATION

PROJ. MANAGER	DESIGN-DETAILED	CHECKED-REVIEWED	DESIGN-DETAILED	REVISIONS 1	REVISIONS 2	REVISIONS 3	REVISIONS 4	FIELD CHANGES
BY	DATE	SIGNATURE	P.E. NUMBER	DATE				

AUBURN
ROUTE 4
CROSS SECTIONS

SHEET NUMBER
OF SHEET

WIN WIN 021766.00 HIGHWAY PLANS

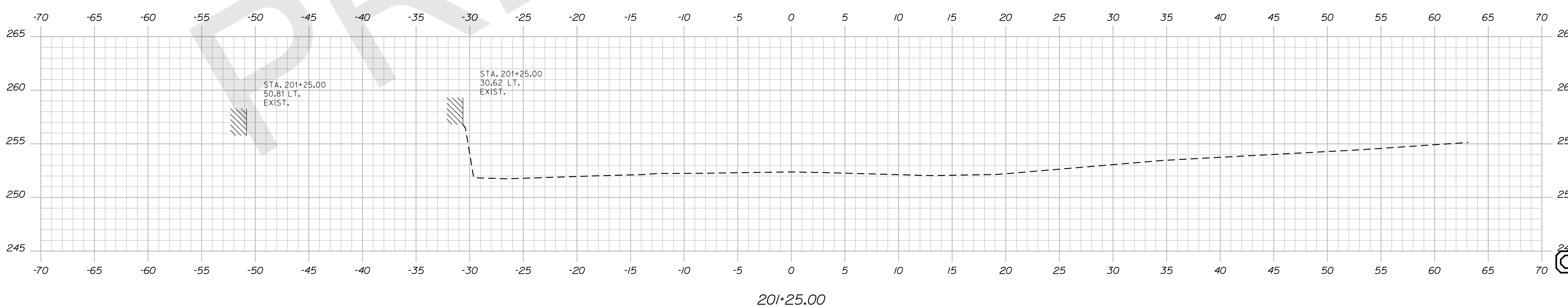
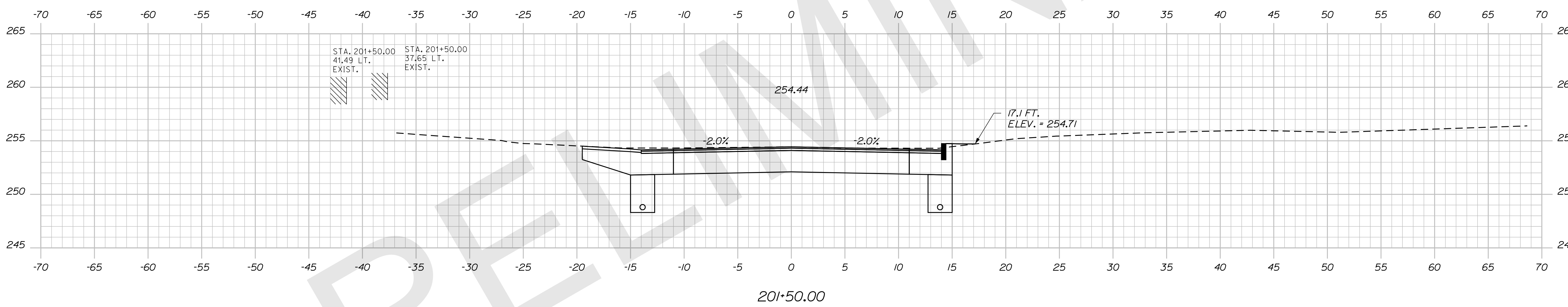
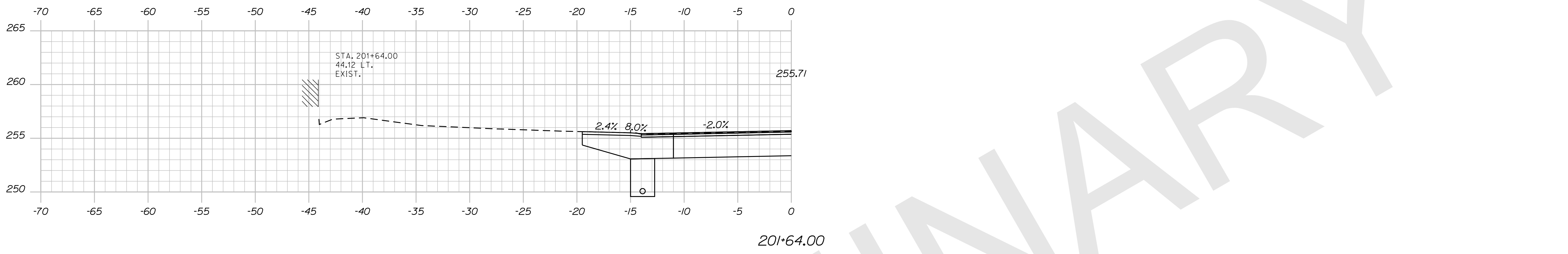

STATE OF MAINE DEPARTMENT OF TRANSPORTATION		SIGNATURE
		P.E. NUMBER
		DATE
PROJ. MANAGER	BY	DATE
DESIGN DETAILED	DESIGNER	DATE
CHECKED/REVIEWED	CHECKER	DATE
DESIGN DETAILED	DESIGNER	DATE
DESIGN DETAILED	DESIGNER	DATE
REVISIONS 1	---	---
REVISIONS 2	---	---
REVISIONS 3	---	---
REVISIONS 4	---	---
FIELD CHANGES	---	---
AUBURN OAK HILL ROAD CROSS SECTIONS		
SHEET NUMBER		
OF SHEET		
OF _		

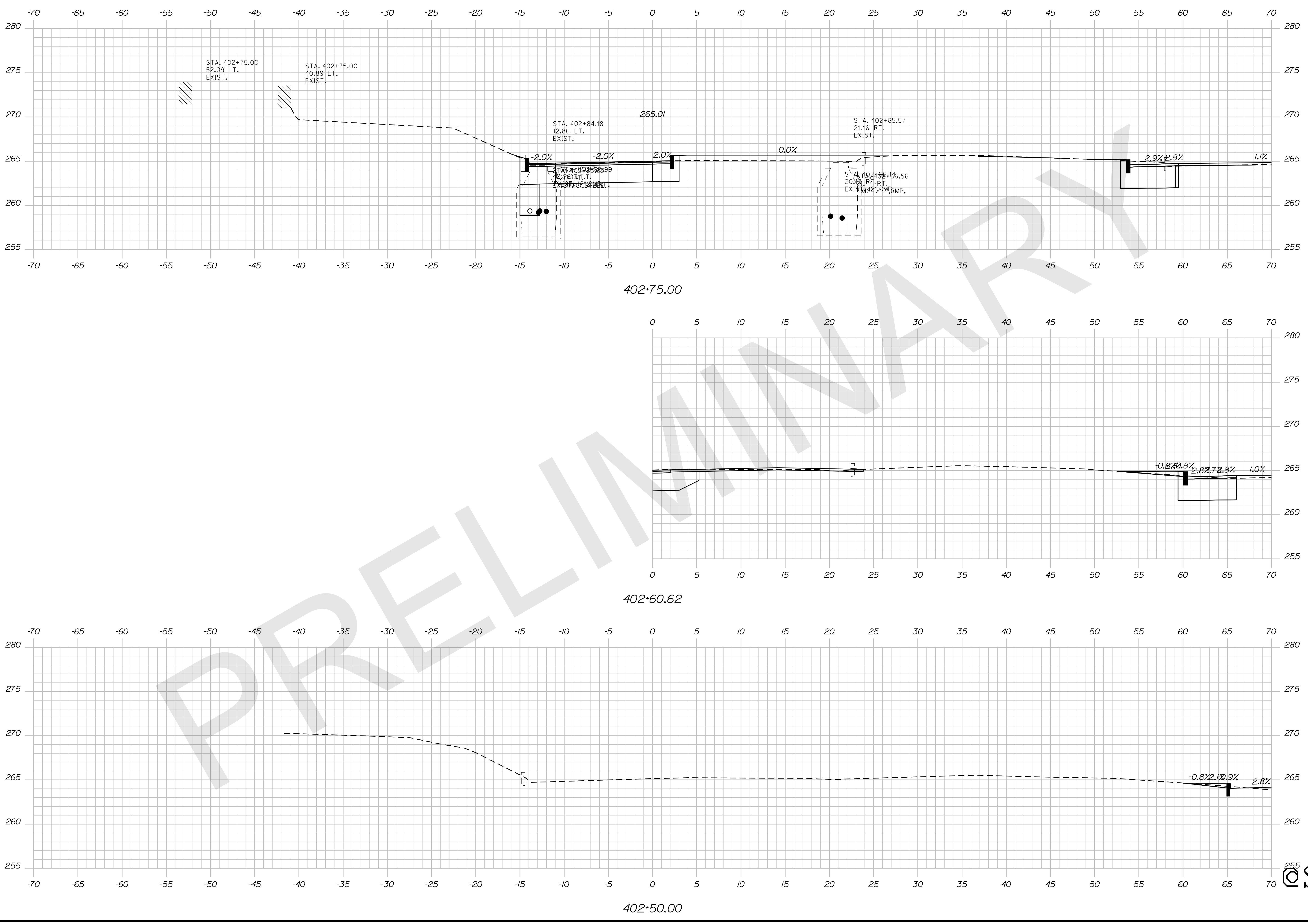

STATE OF MAINE DEPARTMENT OF TRANSPORTATION	
AUBURN TURNER STREET	CROSS SECTIONS
SHEET NUMBER SHEET OF _	
WIN WIN WIN 021766.00 HIGHWAY PLANS	SIGNATURE P.E. NUMBER DATE
PROJ. MANAGER DESIGN DETAILED CHECKED/REVIEWED DESIGN DETAILED REVISIONS 1 REVISIONS 2 REVISIONS 3 REVISIONS 4 FIELD CHANGES	BY DATE DATE DATE DATE DATE DATE DATE

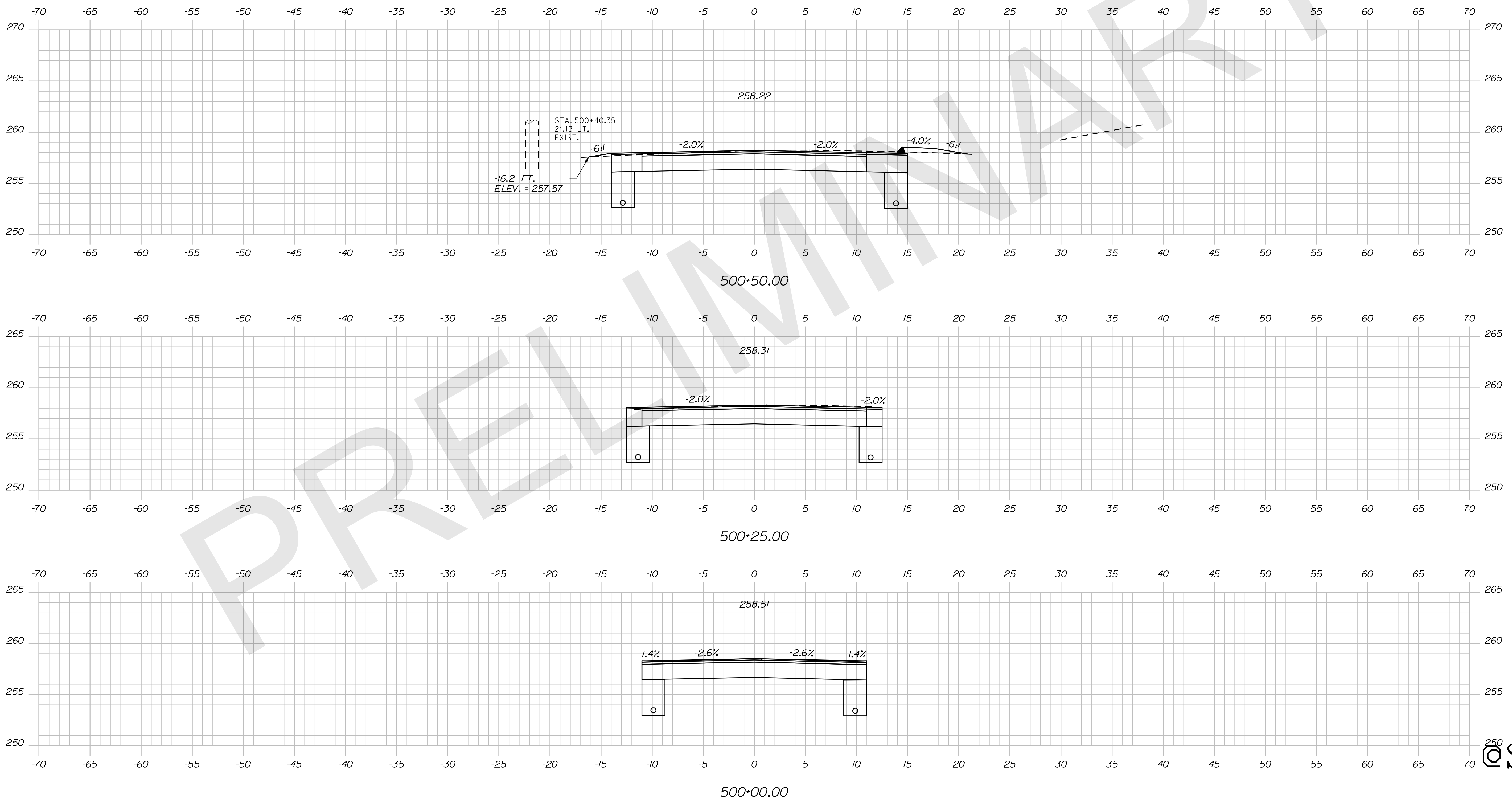

STATE OF MAINE
DEPARTMENT OF TRANSPORTATION

PROJ. MANAGER	DESIGN DETAILED	CHECKED-REVIEWED	DESIGN DETAILED	DESIGN DETAILED	REVISIONS 1	REVISIONS 2	REVISIONS 3	REVISIONS 4	FIELD CHANGES
BY	DATE	SIGNATURE	P.E. NUMBER	DATE					

AUBURN
MARTIN STREET
CROSS SECTIONS

SHEET NUMBER
OF _

Date: 11/18/2019

Username: clark.e.sullivan

Filename: ... \MSTA048_XSECT_500+75_036.dgn Division: HIGHWAY

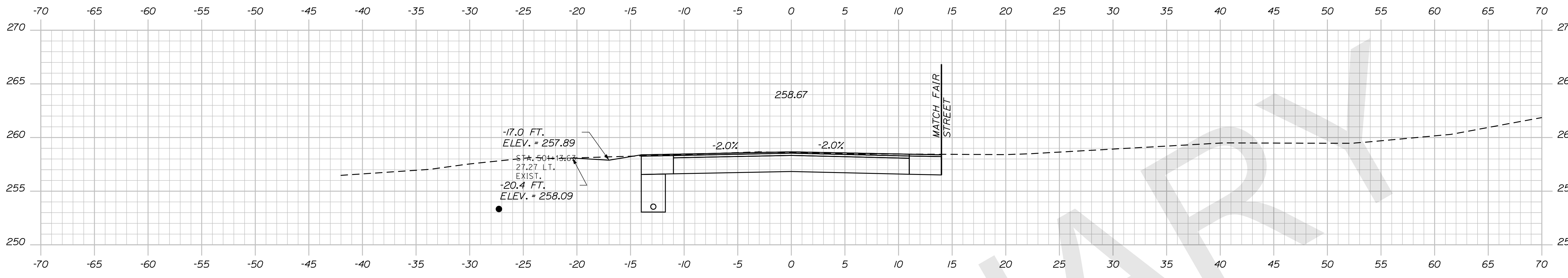

501+25.00

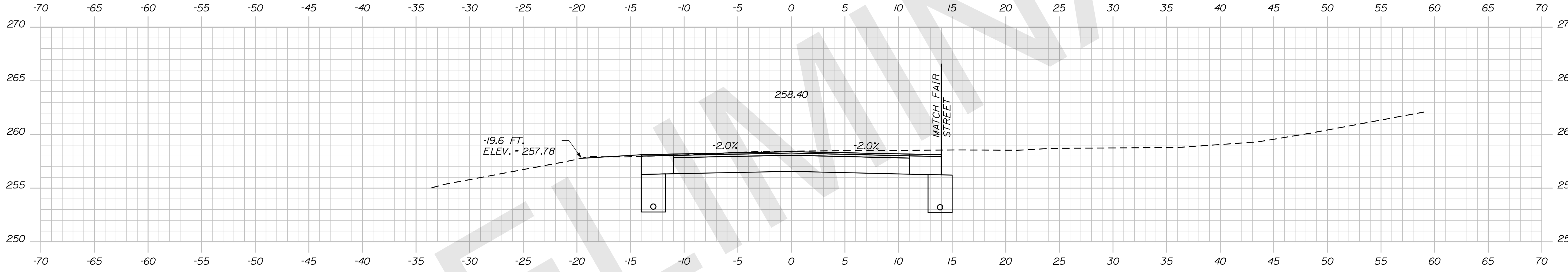

501+00.00

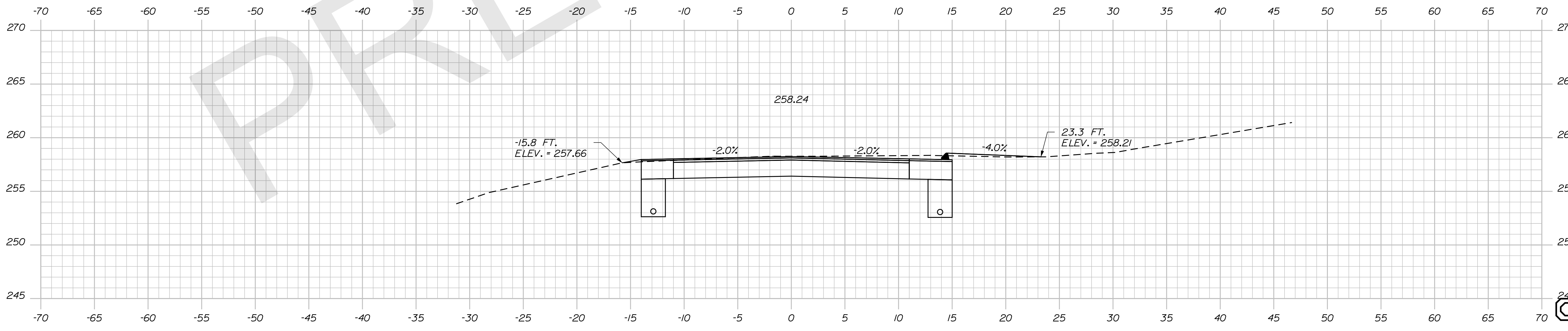

500+75.00

STATE OF MAINE
DEPARTMENT OF TRANSPORTATION

SIGNATURE
P.E. NUMBER
DATE

PROJ. MANAGER	DESIGNER	CHECKER	DATE

AUBURN
MARTIN STREET
CROSS SECTIONS

SHEET NUMBER
OF _

245
SHEET

Sta. 500+75.00 to Sta. 501+25.00

WIN WIN 021766.00 HIGHWAY PLANS

Date: 11/18/2019

Username: clark.e.sullivan

Division: HIGHWAY

Filename: ... \MSTAD049_XSECT_501+50_037.dgn

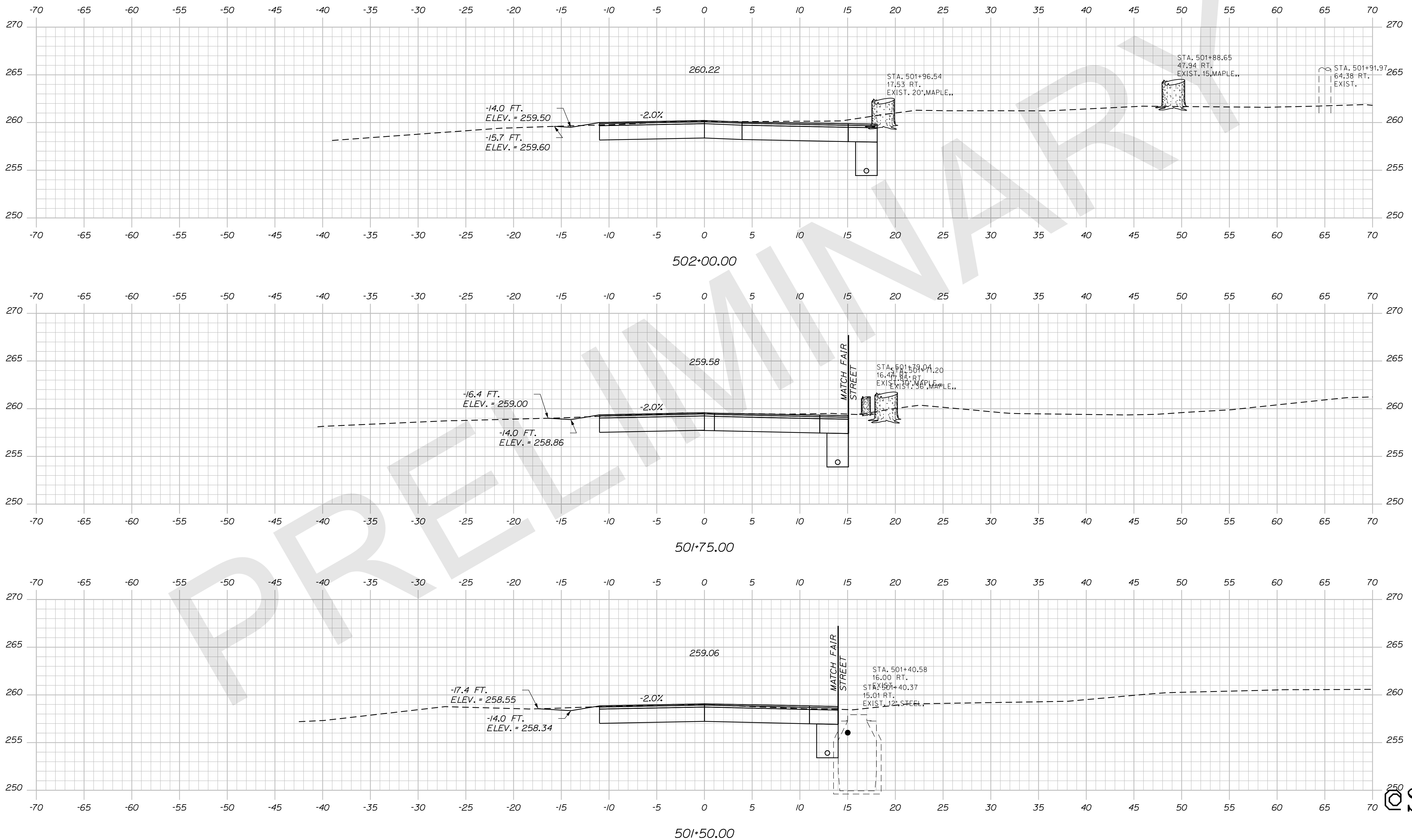

STATE OF MAINE
DEPARTMENT OF TRANSPORTATION

SIGNATURE _____
P.E. NUMBER _____
DATE _____

PROJ. MANAGER	BY	DATE
DESIGN DETAILED	DESIGNER	DATE
CHECKED-REVIEWED	CHECKER	DATE
DESIGN DETAILED	DESIGNER	DATE
DESIGN DETAILED	DESIGNER	DATE
REVISIONS 1	REVISION	DATE
REVISIONS 2	REVISION	DATE
REVISIONS 3	REVISION	DATE
REVISIONS 4	REVISION	DATE
FIELD CHANGES	FIELD	DATE

AUBURN
MARTIN STREET
CROSS SECTIONS

SHEET NUMBER
1
OF **1**

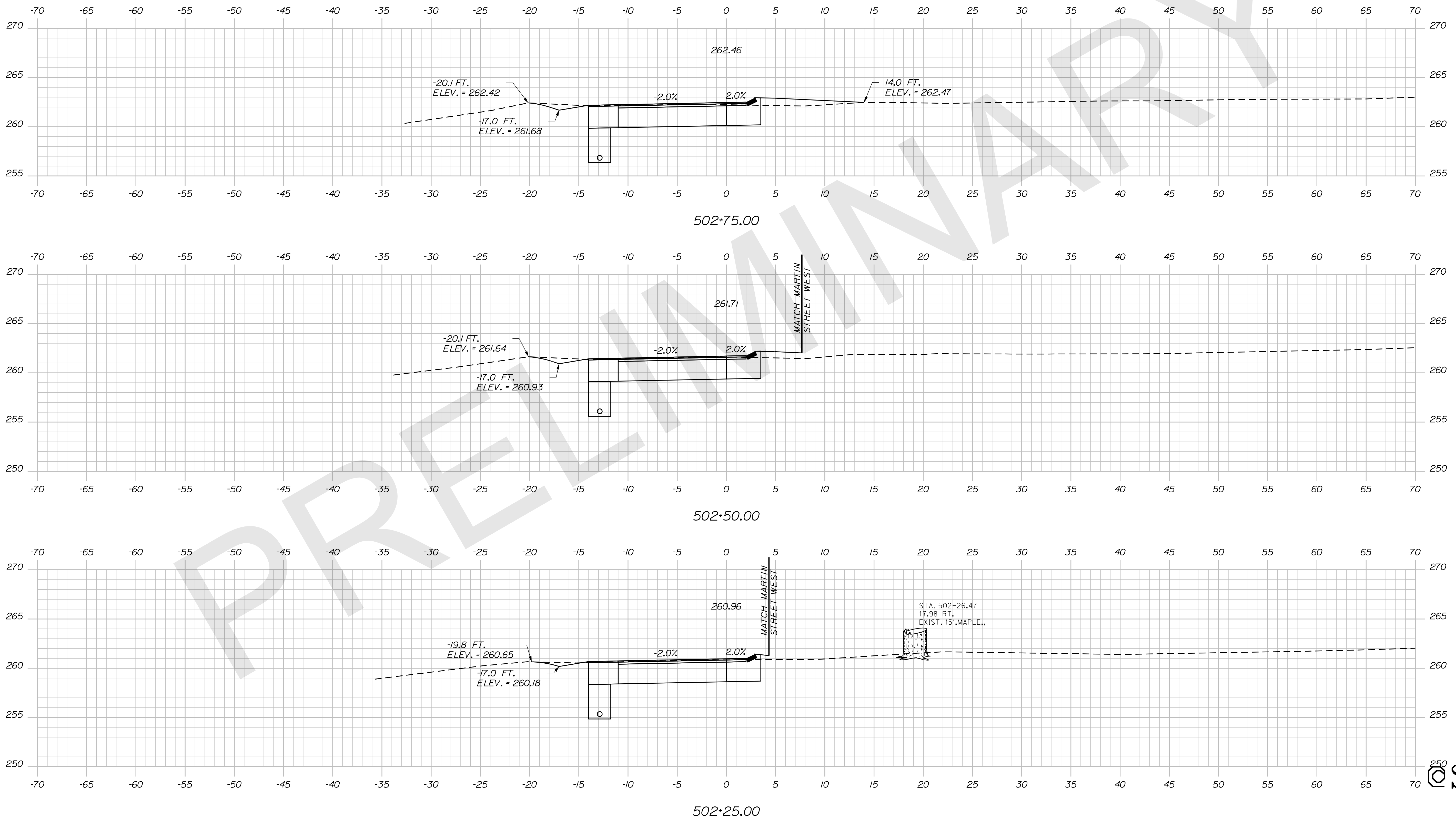

STATE OF MAINE DEPARTMENT OF TRANSPORTATION		WIN WIN WIN 021766.00 HIGHWAY PLANS
	SIGNATURE	P.E. NUMBER
	DATE	DATE
	BY	DATE
	PROJ. MANAGER	\$fieldname3
	DESIGN-DETAILED	\$fieldname1
	CHECKED-REVIEWED	\$fieldname2
	DESIGN-DETAILED	\$fieldname3
	DESIGN-DETAILED	\$fieldname4
	REVISIONS 1	\$fieldname5
	REVISIONS 2	\$fieldname6
	REVISIONS 3	\$fieldname7
	REVISIONS 4	\$fieldname8
	FIELD CHANGES	\$fieldname9
AUBURN MARTIN STREET CROSS SECTIONS		
SHEET NUMBER		
OF SHEET		
OF _		

Date: 11/18/2019

Username: clark.e.sullivan

Division: HIGHWAY

Filename: ... \MSTAD051_XSECT_503+00_039.dgn

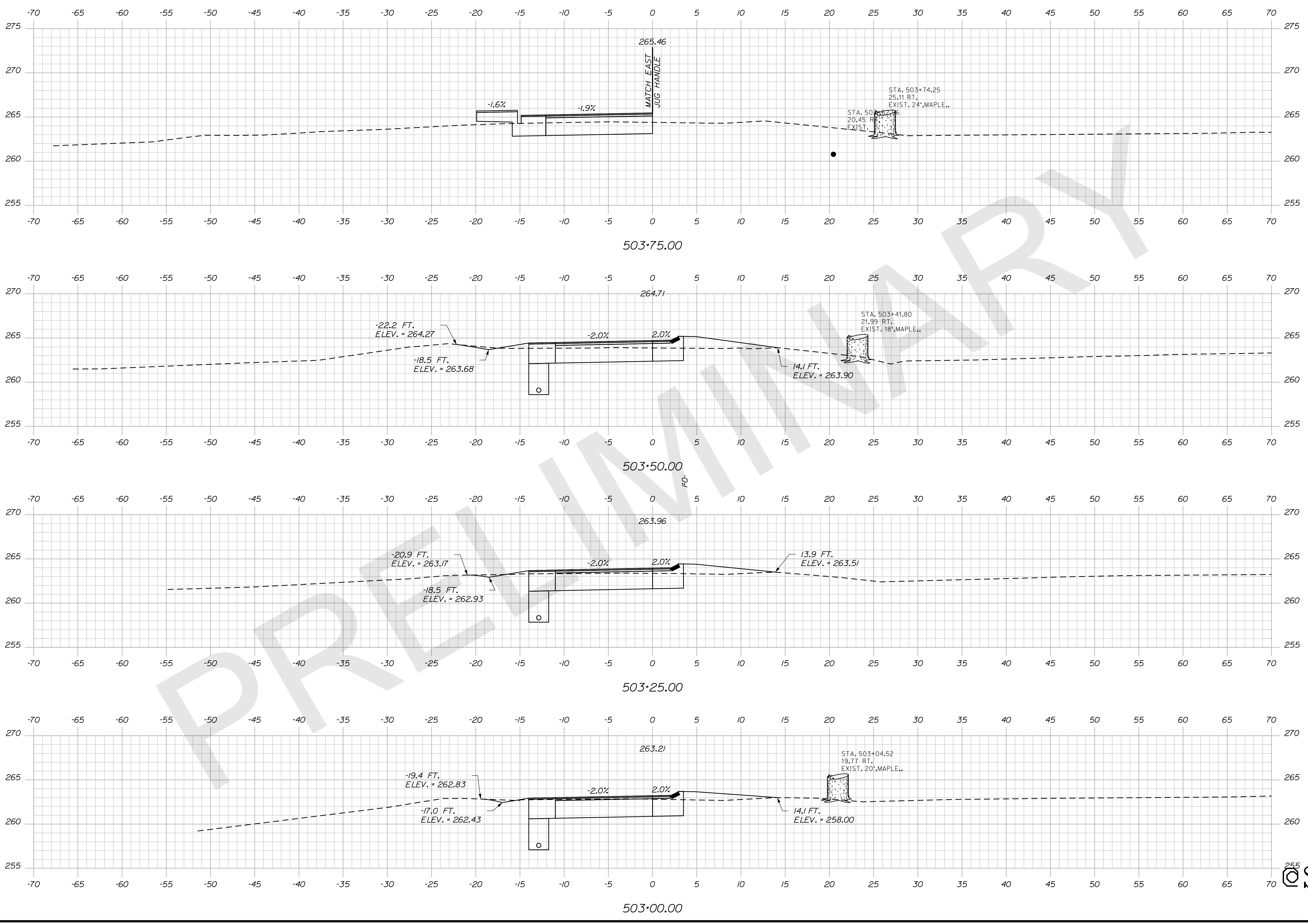

STATE OF MAINE
DEPARTMENT OF TRANSPORTATION

AUBURN
MARTIN STREET

PROJ. MANAGER	DESIGN-DETAILED	CHECKED-REVIEWED	DESIGN-DETAILED	DESIGN-DETAILED	REVISIONS 1	REVISIONS 2	REVISIONS 3	REVISIONS 4	FIELD CHANGES

CROSS SECTIONS

SHEET NUMBER
255
OF **255**

WIN
WIN WIN 021766.00
HIGHWAY PLANS

Date: 11/18/2019

Username: clark.e.sullivan

Filename: ... \MSTAD052_XSECT_503+88_040.dgn Division: HIGHWAY

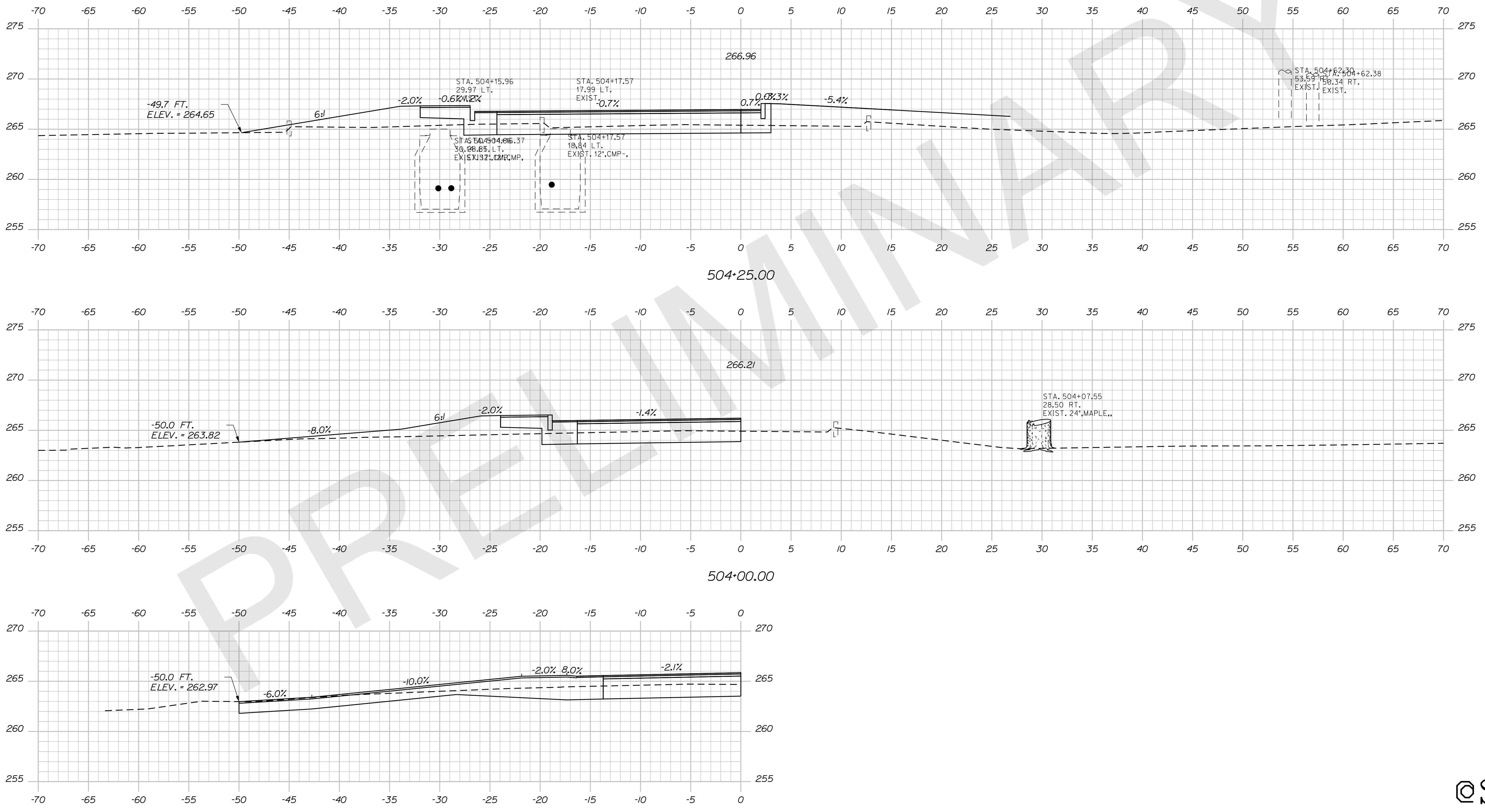

STATE OF MAINE
DEPARTMENT OF TRANSPORTATION

PROJ. MANAGER	BY	DATE	SIGNATURE
CHECKED-REVIEWED	DESIGNER	DATE	P.E. NUMBER
DESIGN DETAIL	DESIGNER	DATE	DATE
DESIGN DETAIL	DESIGNER	DATE	DATE
REVISIONS 1	DESIGNER	DATE	DATE
REVISIONS 2	DESIGNER	DATE	DATE
REVISIONS 3	DESIGNER	DATE	DATE
REVISIONS 4	DESIGNER	DATE	DATE
FIELD CHANGES	DESIGNER	DATE	DATE

AUBURN
MARTIN STREET
CROSS SECTIONS

SHEET NUMBER
OF _

Date: 11/18/2019

Username: clark.e.sullivan

Division: HIGHWAY

Filename: ... \MSTAD053_XSECT_600+75_041.dgn

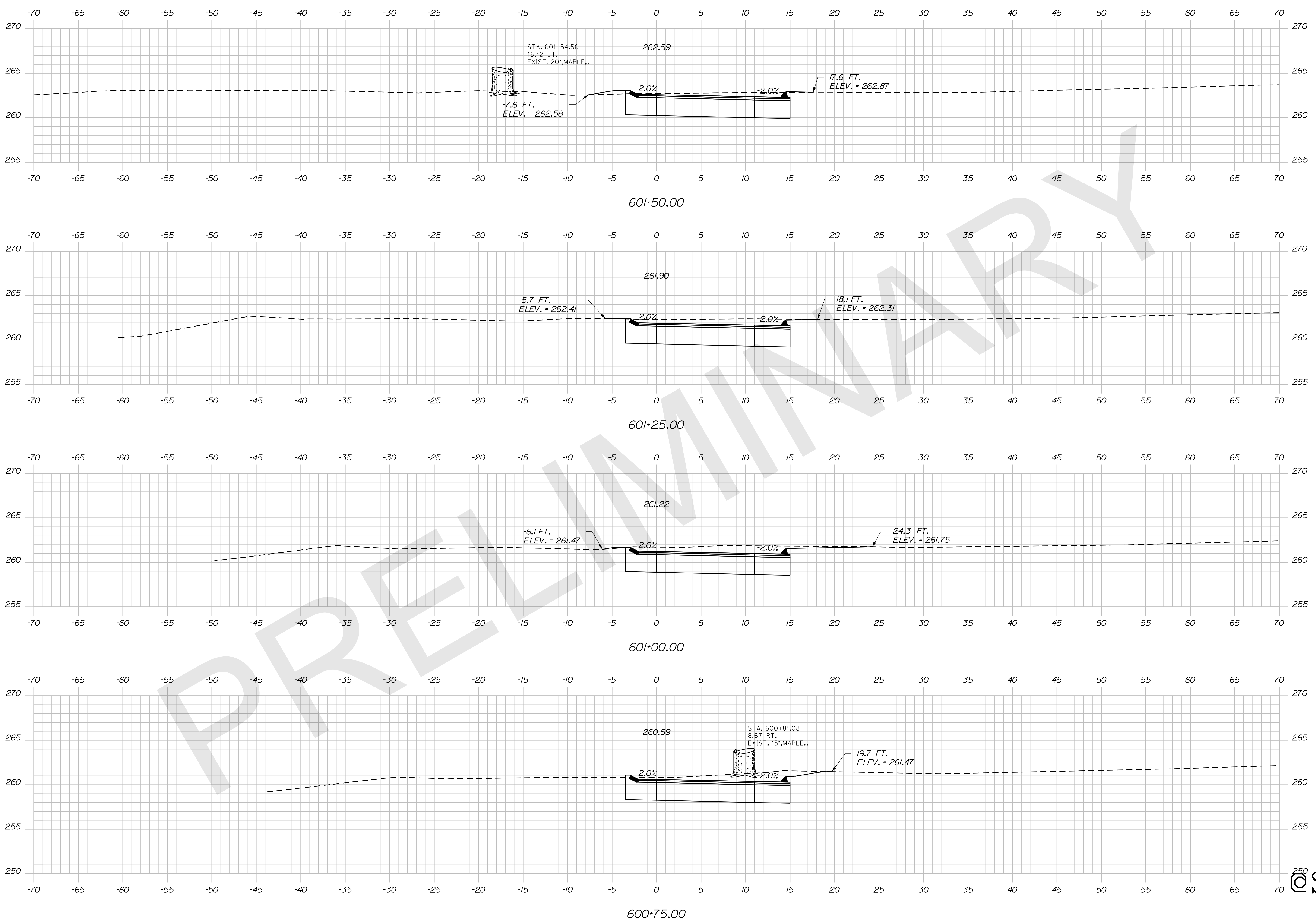

STATE OF MAINE
DEPARTMENT OF TRANSPORTATION

PROJ. MANAGER	BY	DATE	SIGNATURE
DESIGN-DETAILED	DESIGNER	DATE	
CHECKED-REVIEWED	DESIGNER	DATE	
DESIGN-DETAILED	DESIGNER	DATE	
DESIGN-DETAILED	DESIGNER	DATE	
REVISIONS 1	DESIGNER	DATE	
REVISIONS 2	DESIGNER	DATE	
REVISIONS 3	DESIGNER	DATE	
REVISIONS 4	DESIGNER	DATE	
FIELD CHANGES	DESIGNER	DATE	

AUBURN STREET
MARTIN STREET
CROSS SECTIONS

SHEET NUMBER
OF SHEET

Date: 11/18/2019

Username: clark.e.sullivan

Division: HIGHWAY

Filename: ... \MSTAD054_XSECT_601+75_042.dgn

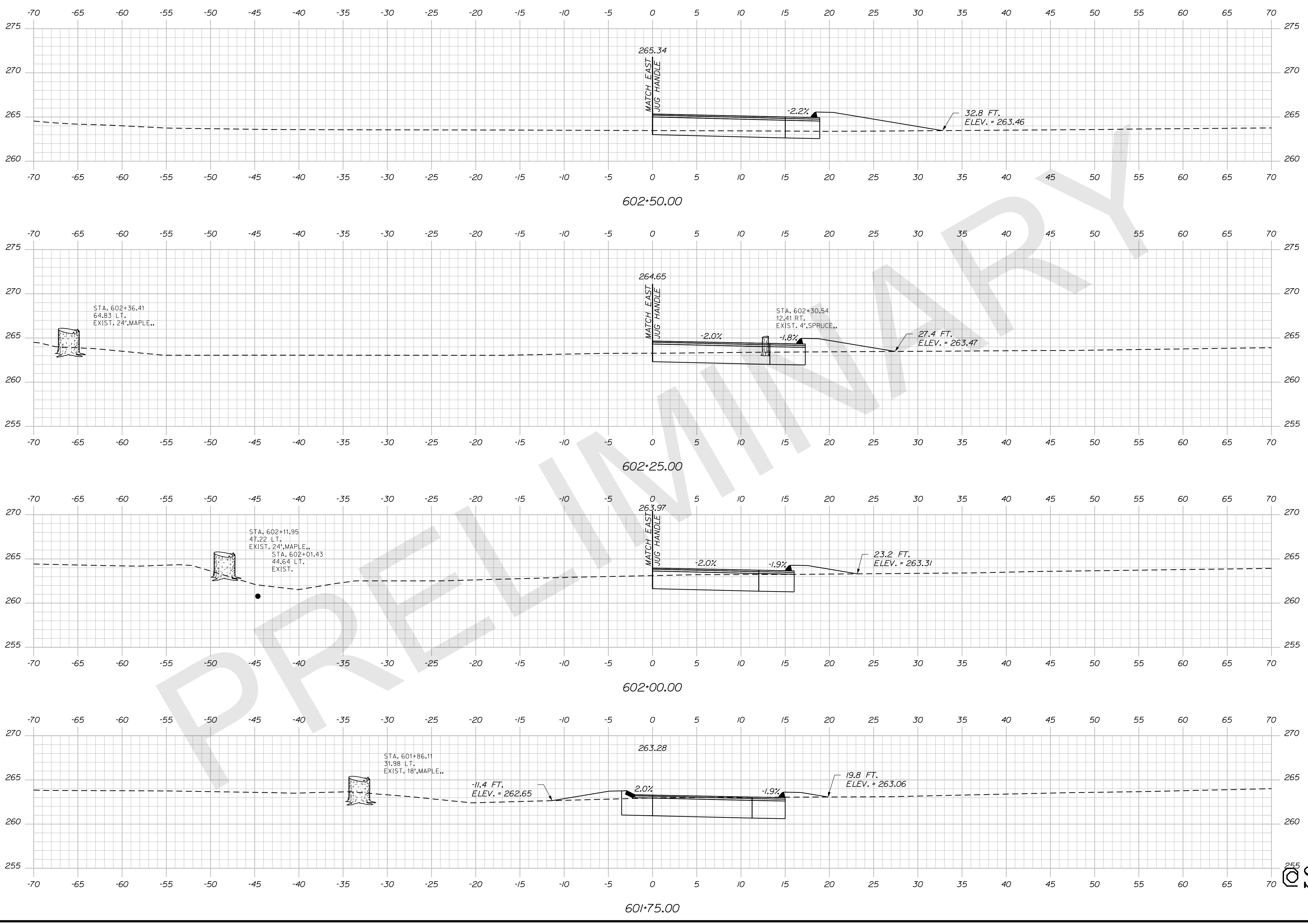

STATE OF MAINE DEPARTMENT OF TRANSPORTATION		SIGNATURE	
WIN WIN WIN 021766.00 HIGHWAY PLANS		P.E. NUMBER	
DATE		DATE	
PROJ. MANAGER	DESIGNER	BY	DATE
CHECKED-REVIEWED	DESIGNER	DESIGNER	DATE
DESIGN DETAILED	DESIGNER	DESIGNER	DATE
REVISIONS 1	DESIGNER	DESIGNER	DATE
REVISIONS 2	DESIGNER	DESIGNER	DATE
REVISIONS 3	DESIGNER	DESIGNER	DATE
REVISIONS 4	DESIGNER	DESIGNER	DATE
FIELD CHANGES	DESIGNER	DESIGNER	DATE

AUBURN
MARTIN STREET
CROSS SECTIONS

SHEET NUMBER
OF SHEET

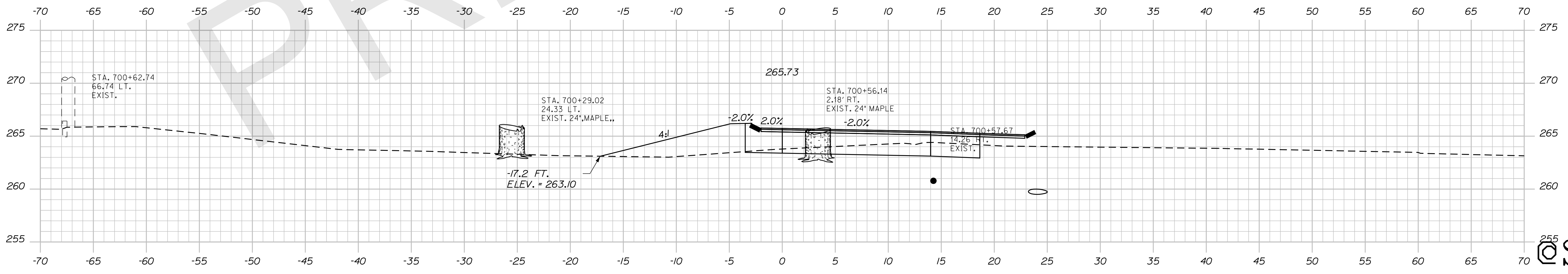
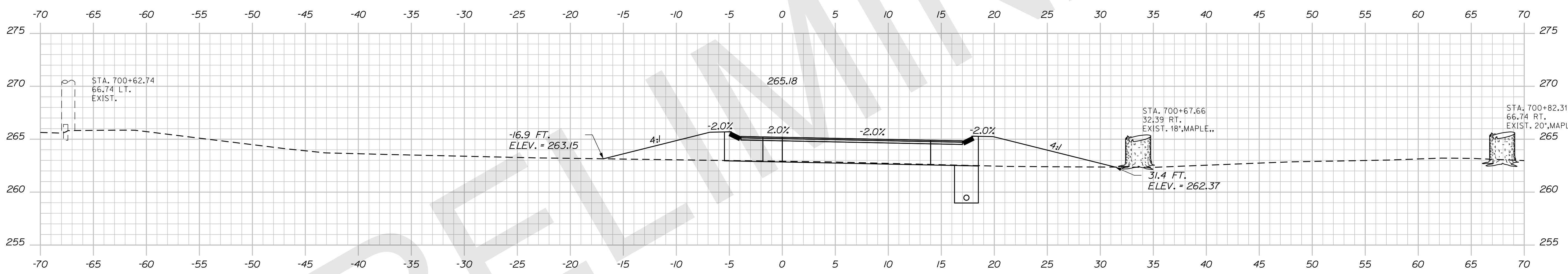

STATE OF MAINE
 DEPARTMENT OF TRANSPORTATION

PROJ. MANAGER	DESIGN DETAILED	CHECKED/REVIEWED	DATE
BY	DATE	BY	DATE
DESIGN DETAILED	DATE	DESIGN DETAILED	DATE
REVISIONS 1	DATE	REVISIONS 1	DATE
REVISIONS 2	DATE	REVISIONS 2	DATE
REVISIONS 3	DATE	REVISIONS 3	DATE
REVISIONS 4	DATE	REVISIONS 4	DATE
FIELD CHANGES	DATE	FIELD CHANGES	DATE

AUBURN
 EAST JUG HANDLE
 CROSS SECTIONS

SHEET NUMBER
 OF SHEET

Username: clark.e.sullivan Date: 11/18/2019

Division: HIGHWAY

Filename: ... \MSTAD056_XSECT_800+25_044.dgn

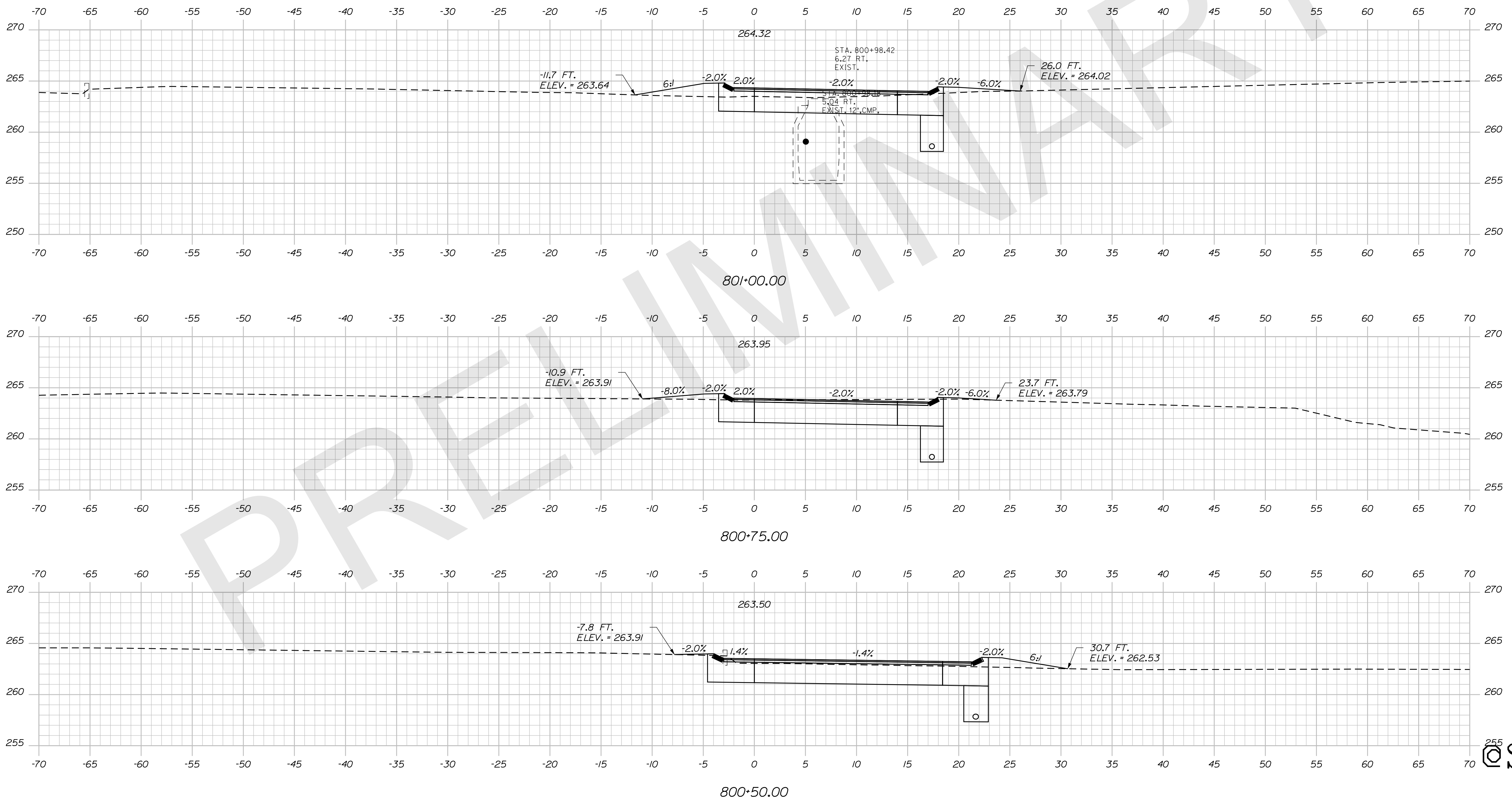

STATE OF MAINE
DEPARTMENT OF TRANSPORTATION

PROJ. MANAGER	DESIGN DETAILED	CHECKED/REVIEWED	DESIGN DETAILED	DESIGN DETAILED	REVISIONS 1	REVISIONS 2	REVISIONS 3	REVISIONS 4	FIELD CHANGES	BY	DATE	SIGNATURE

AUBURN
WEST JUG HANDLE
CROSS SECTIONS

SHEET NUMBER
OF _

Date: 11/18/2019

Username: clark.e.sullivan

Filename: ... \MSTAD057_XSECT_801+25_045.dgn Division: HIGHWAY

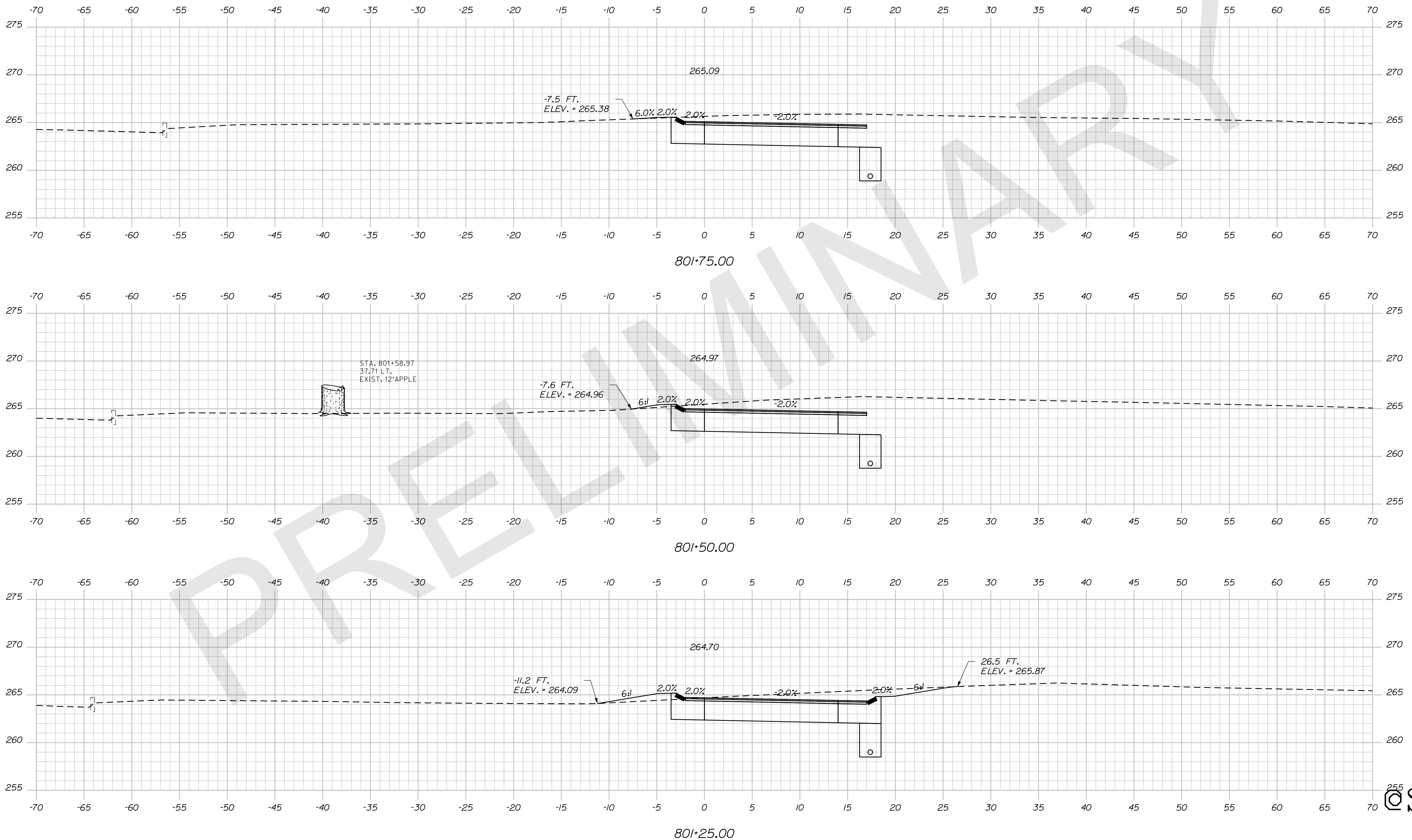

STATE OF MAINE
DEPARTMENT OF TRANSPORTATION

SIGNATURE
P.E. NUMBER
DATE

PROJ. MANAGER	DESIGNER	CHECKER	DATE
PROJMANAGER1	DESIGNER1	CHECKER1	DATE1
PROJMANAGER2	DESIGNER2	CHECKER2	DATE2
PROJMANAGER3	DESIGNER3	CHECKER3	DATE3
PROJMANAGER4	DESIGNER4	CHECKER4	DATE4
PROJMANAGER5	DESIGNER5	CHECKER5	DATE5

AUBURN
WEST JUG HANDLE
CROSS SECTIONS

SHEET NUMBER
10
OF 1

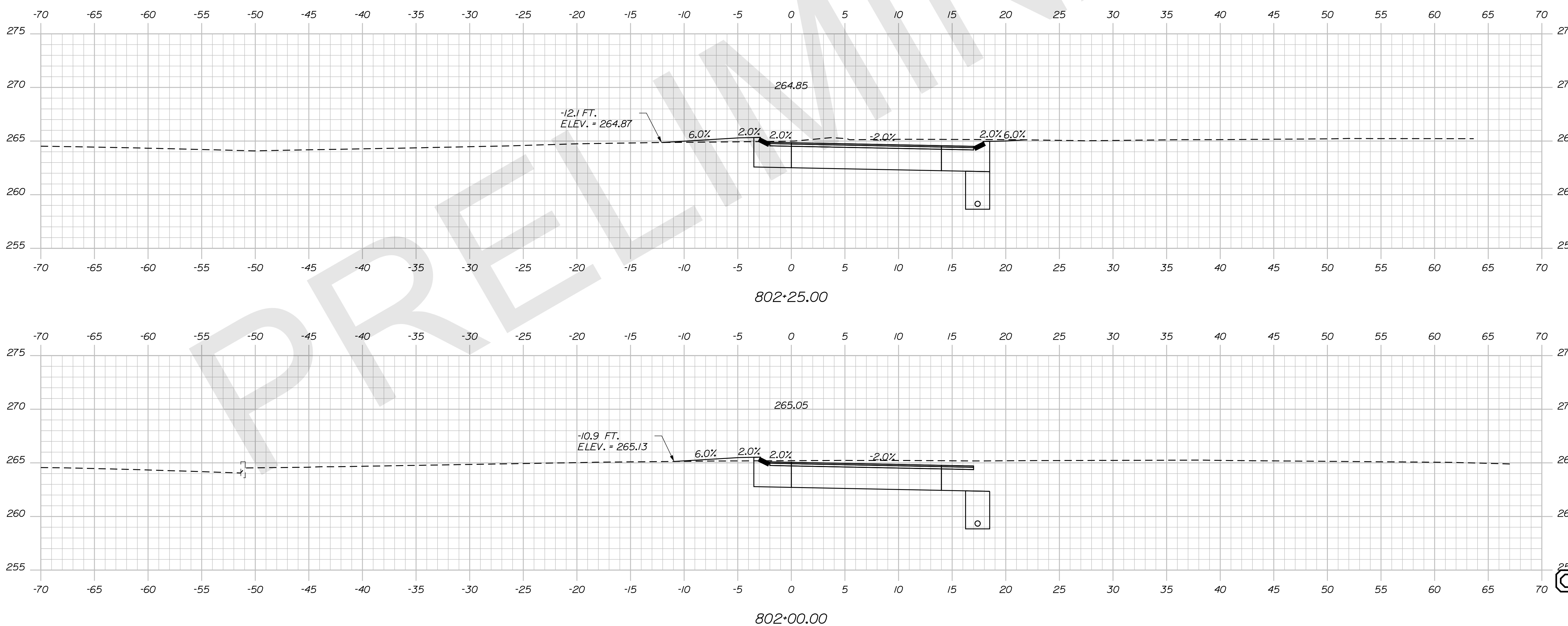

STATE OF MAINE
DEPARTMENT OF TRANSPORTATION

PROJ. MANAGER	BY	DATE	SIGNATURE
DESIGN-DETAILED	DESIGNER	DATE	
CHECKED-REVIEWED	CHECKER	DATE	
DESIGN-DETAILED	DESIGNER	DATE	
DESIGN-DETAILED	DESIGNER	DATE	
REVISIONS 1	REVISION	DATE	
REVISIONS 2	REVISION	DATE	
REVISIONS 3	REVISION	DATE	
REVISIONS 4	REVISION	DATE	
FIELD CHANGES	FIELD	DATE	

AUBURN
WEST JUG HANDLE
CROSS SECTIONS

SHEET NUMBER
OF _

WIN
WIN WIN 021766.00 HIGHWAY PLANS